 在本使用说明书中，我们将尽力叙述各种与 XJT 系列交流永磁同步直线电动机相关的事项。限于篇幅限制及产品具体使用等原因，不可能对所有不必做和/或不能做的操作进行详细的叙述。因此，本使用说明书中没有特别指明的事项均视为“不可能”或“不允许”进行的操作。

 本使用说明书的版权，归广州数控设备有限公司所有，任何单位与个人进行出版或复印均属于非法行为，广州数控设备有限公司将保留追究其法律责任的权利。

## 前 言

尊敬的客户：

对您惠顾选用广州数控设备有限公司的 GSK XJT 系列交流永磁同步直线电动机（以下简称直线电动机），本公司深感荣幸并深表感谢！

为了保证电动机产品安全、正常与有效地运行工作，请您务必在安装、使用产品前仔细阅读本使用说明书。

## 安全警告及注意事项



安装及操作不当，易引起意外事故！

请安装使用之前，务必仔细阅读本使用说明书！

初级组件警告标识：



高温危险



高压危险

次级组件警告标识：

靠近警示：



强磁危险



其他注意事项：

- 1 请于安装使用前，先确认直线电动机（包含初级组件和次级组件及冷却附件）是否有破损或毁坏，若有任何破损情况，请及时与本司或经销商联络。
- 2 在正常气候条件下，用 500V 兆欧表测量初级组件绕组三相 U、V、W 对地线及外壳的绝缘电阻，其值应不小于 20 MΩ 。
- 3 组装和操作时，必须交由专业人员进行。
- 4 次级组件拆装时，应避免金属物件拷机，并特别注意手部夹伤风险，务必谨慎处理。
- 5 接线时，请按电源线标识的 U、V、W 与驱动单元 U、V、W 对应接线并确保接地牢固可靠。
- 6 用户对产品的任何私自改动本公司将不承担任何责任，产品的保修单将因此作废。

所有型号规格和设计如有变化，恕不另行通知！

## 安全责任

### 制造者的安全责任

- 制造者应对所提供的直线电动机及随行供应的附件在设计和结构上已消除和/或控制的危险负责。
- 制造者应对所提供的直线电动机及随行供应的附件的安全负责。
- 制造者应对提供给使用者的使用信息和建议负责。

### 使用者的安全责任

- 使用者应通过直线电动机安全操作的学习和培训，并熟悉和掌握安全操作的内容。
- 使用者应对自己增加、变换或修改原直线电动机、附件后的安全及造成的危险负责。
- 使用者应对未按使用说明文件的规定操作、调整、维护、安装和储运产品造成的危险负责。

本手册由最终用户收藏。

诚挚的感谢——您在使用广州数控设备有限公司的产品时，

对我们的友好支持！

## 目 录

<b>1</b>	<b>产品特点</b> .....	<b>1</b>
<b>2</b>	<b>型号说明</b> .....	<b>1</b>
<b>3</b>	<b>主要技术参数</b> .....	<b>2</b>
3.1	88XJT 系列电动机的主要技术参数.....	2
3.2	100XJT 系列电动机的主要技术参数.....	3
3.3	134XJT 系列电动机的主要技术参数.....	4
3.4	182XJT 系列电动机的主要技术参数.....	6
3.5	242XJT 系列电动机的主要技术参数.....	8
3.6	334XJT 系列电动机的主要技术参数.....	10
3.7	340XJT 系列电动机的主要技术参数.....	12
<b>4</b>	<b>外形及安装尺寸</b> .....	<b>13</b>
4.1	88XJT 系列电动机外形及安装尺寸.....	13
4.2	100XJT 系列电动机外形及安装尺寸.....	13
4.3	134XJT 系列电动机外形及安装尺寸.....	14
4.4	182XJT 系列电动机外形及安装尺寸.....	15
4.5	242XJT 系列电动机外形及安装尺寸.....	16
4.6	334XJT 系列电动机外形及安装尺寸.....	17
4.7	340XJT 系列电动机外形及安装尺寸.....	18
<b>5</b>	<b>安装要求及注意事项</b> .....	<b>19</b>
5.1	直线电动机组成.....	19
5.2	安装结构.....	20
5.3	安装要求.....	20
5.4	安装顺序.....	21
5.5	气隙对连续推力的影响.....	21
5.5	并联使用.....	22
5.6	其他安装注意事项.....	23
<b>6</b>	<b>直线电动机选型</b> .....	<b>23</b>
6.1	直线电动机的选型计算方法.....	23
6.2	直线电动机配套驱动的选型.....	24
<b>7</b>	<b>发热功率计算及水冷机选用</b> .....	<b>25</b>
7.1	直线电动机冷却水路安装.....	25
7.2	直线电动机发热功率计算.....	25
7.3	冷水机的选用.....	25
<b>8</b>	<b>直线电动机线缆</b> .....	<b>26</b>
8.1	温度保护配置.....	26

8.1.1	KTY84/130 硅热敏电阻 .....	26
8.1.2	PTC130 过热保护温度传感器 .....	27
8.2	温控信号线 (XJT-00-701) .....	28
8.3	电源线 .....	28
<b>9</b>	<b>电动机的贮存 .....</b>	<b>29</b>
<b>10</b>	<b>电动机的运输 .....</b>	<b>29</b>
<b>11</b>	<b>质量保证期 .....</b>	<b>29</b>
<b>12</b>	<b>订货说明 .....</b>	<b>29</b>

## 1 产品特点

广州数控设备有限公司自主开发及制造的 XJT 系列永磁交流同步直线电动机，采用高性能的稀土永磁材料，具有高功率密度、高动态响应、低推力波动、高可靠性等特点，能满足数控机床及自动化设备等方面的广泛需求。

直线电动机因其原理和结构上的特点，与“丝杆+旋转电动机结构”相比，其优势主要表现为以下方面：

- **结构简单：**机械结构相对简单，机械传动件、部件少。
- **高速度：**初级部件安装在可高速运行的导轨上，不受传统的丝杆、轴承等机械配件使用极限的制约。可获得较高且平稳的速度和加速度（实测可达 4g）。
- **高动态响应：**驱动力直接传递，实现了在具有很高的动态性能的同时达到很好的精度且没有过冲。
- **高精度：**配备高精度直线编码器，使各个速度段均能获得很高的精度。
- **精度保持性：**取消了丝杆、轴承等易磨损件，理论上“零磨损”，使精度保持性更优异。
- **行程无限制：**不受丝杆长度及自身刚度的影响，在行程上可以无限延长。

## 2 型号说明

示例：

$\underline{134}$     $\underline{XJT}$     $\underline{1K2}$     $\underline{M}$     $\underline{10}$     $\underline{W}$   
 ①   ②   ③   ④   ⑤   ⑥

序号	含义
①	框架号。
②	永磁同步直线电动机。
③	直线电动机的额定推力（用三位数表示，单位：N。小于 1000N，直接用三位数表示，如 050 表示 50N，645 表示 645N；大于 1000N，用□K□表示，如 1K2 表示 1200N，8K1 表示 8100N；大于 10000N，用□□K 表示，如 13K，表示 13000N，17K 表示 17000N）。
④	驱动单元输入电压（L：220V，M：380V）。
⑤	额定速度代号（用两位数表示，其值为两位数字×0.1，单位：m/s。 如，20×0.1=2 m/s，13×0.1=1.3 m/s）。
⑥	冷却方式（W：水冷，N：自冷）。

### 3 主要技术参数

#### 3.1 88XJT 系列直线电动机的主要技术参数

表 1

项目	型号	
	88XJT260L20N	88XJT260M20N
额定功率 (kW)	0.52	
极距 $2\tau$ (mm)	30	
驱动单元输入电压	单相 AC 220V	三相 AC 380V
连续推力 (N)	260	260
连续电流 (A)	4.3	2.3
峰值推力 (N)	1000	1000
峰值电流 (A)	16.2	8.9
额定速度 (m/s)	2	2
最高速度 (m/s)	4	4
推力常数 (N/A)	60.5	113
相反电势常数 (Vs/m)	21.5	39.9
25℃相电阻 ( $\Omega$ )	1.84	6.85
120℃相电阻 ( $\Omega$ )	2.52	9.35
正向吸力 (N)	1700	1700
初级规格	88XJT260L20-00	88XJT260M20-00
初级重量 (kg)	3.6	
绝缘等级	F (GB/T 755—2019/IEC 60034-1: 2017)	
防护等级	IP65 (GB/T 4208—2017/IEC 60529: 2013, GB/T 4942—2021/IEC 60034-5: 2020)	
次级规格	100XJTS4-00	
次级重量/件 (kg)	0.7 (单件长 120mm)	

推力—速度特性图 (F-n) (A: 连续工作区; B: 短时工作区)

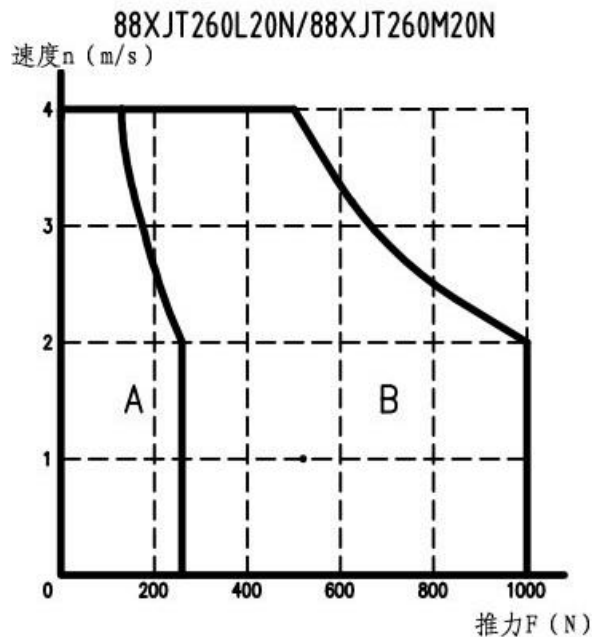



3.2 100XJT 系列直线电动机的主要技术参数

表 2

项目	型号	
	100XJT400M20W	100XJT600M20W
额定功率 (kW)	0.8	1.2
极距 $2\tau$ (mm)	30	
驱动单元输入电压 (V)	三相 AC380	
连续推力 (N)	400 (200)	600 (300)
连续电流 (A)	4.5	6.5
峰值推力 (N)	1000	1500
峰值电流 (A)	12	17
额定速度 (m/s)	2	2
最高速度 (m/s)	4	4
推力常数 (N/A)	88.8	92.3
相反电势常数 (Vs/m)	30.8	32.2
25℃相电阻 ( $\Omega$ )	4.3	3.49
120℃相电阻 ( $\Omega$ )	5.87	4.76
正向吸力 (N)	2600	3900
冷却最小流量 (L/min)	2.5	
初级规格	100XJT400M20-00	100XJT600M20-00
初级重量 (kg)	4	5.6
绝缘等级	F (GB/T 755—2019/IEC 60034-1: 2017)	
防护等级	IP65 (GB/T 4208—2017/IEC 60529: 2013, GB/T 4942—2021/IEC 60034-5: 2020)	
次级规格	100XJTS4-00	
次级重量/件 (kg)	0.7 (单件长 120mm)	
精密冷却罩 (选配)	100XJT400-02	100XJT600-02
精密冷却罩重量 (kg)	0.6	0.8

注：括号内为不通水时连续推力指标。

推力—速度特性图 (F-n) (A: 连续工作区; B: 短时工作区)

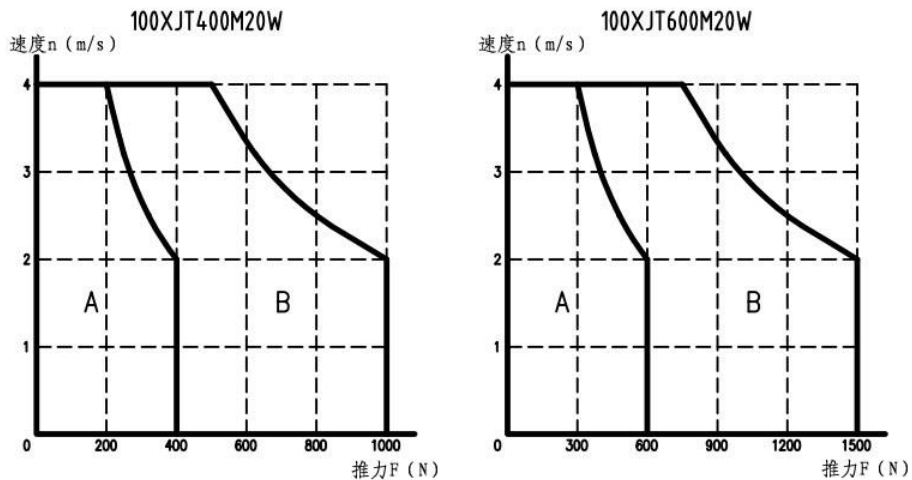

3.3 134XJT 系列直线电动机的主要技术参数

表 3

项目	型号		
	134XJT1K2L10W	134XJT1K8L10W	134XJT2K4L10W
额定功率 (kW)	1.2	1.8	2.4
极距 2τ (mm)	46		
驱动单元输入电压	单相 AC 220V		
连续推力 (N)	1200 (600)	1800 (900)	2400 (1200)
连续电流 (A)	10	14	18
峰值推力 (N)	3000	4500	6000
峰值电流 (A)	25	35	45
额定速度 (m/s)	1	1	1
最高速度 (m/s)	1.5	1.5	1.5
推力常数 (N/A)	120	129	134
相反电势常数 (Vs/m)	44	45	48
25℃相电阻 (Ω)	2.0	1.7	1.02
120℃相电阻 (Ω)	2.75	2.37	1.39
正向吸力 (N)	6800	10200	13600
冷却最小流量 (L/min)	2.5		
初级规格	134XJT1K2L10-00	134XJT1K8L10-00	134XJT2K4L10-00
初级重量 (kg)	12	17	22
绝缘等级	F (GB/T 755—2019/IEC 60034-1: 2017)		
防护等级	IP65 (GB/T 4208—2017/IEC 60529: 2013, GB/T 4942—2021/IEC 60034-5: 2020)		
次级规格	140XJTS4-01		
次级重量/件 (kg)	2.4 (单件长 184mm)		
精密冷却罩 (选配)	134XJT1K2-02	134XJT1K8-02	134XJT2K4-02
精密冷却罩重量 (kg)	0.9	1.3	1.7

注：括号内为不通水时连续推力指标。

推力—速度特性图 (F-n) (A: 连续工作区; B: 短时工作区)

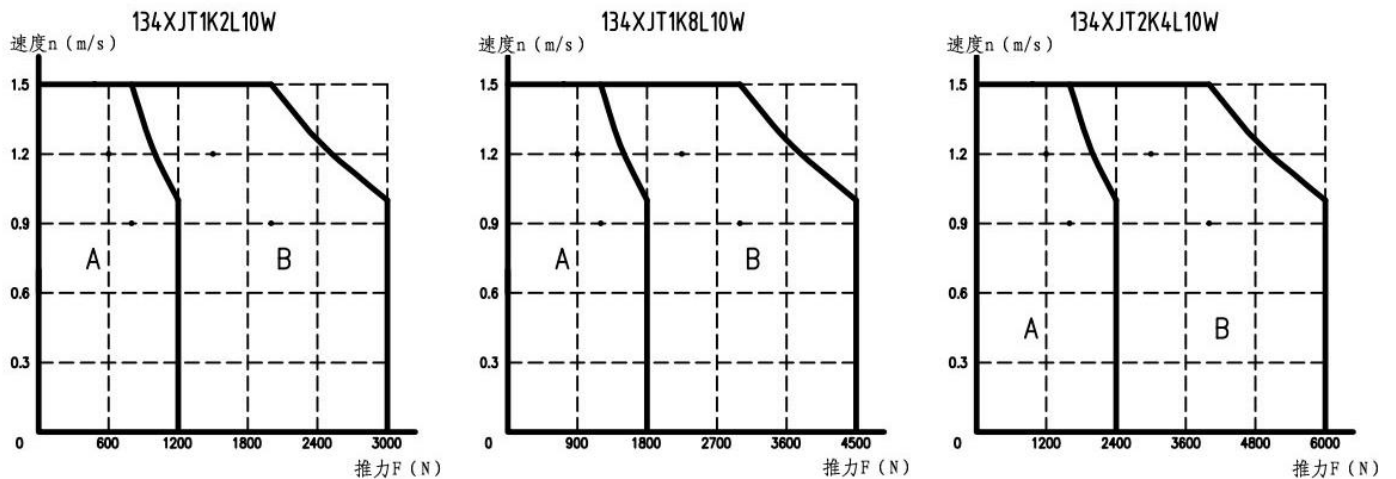

产品技术参数

表 3 (续)

项目	规格		
	134XJT1K2M10W	134XJT1K8M10W	134XJT2K4M10W
额定功率 (kW)	1.2	1.8	2.4
极距 $2\tau$ (mm)	46		
驱动单元输入电压 (V)	三相 AC 380V		
连续推力 (N)	1200 (600)	1800 (900)	2400 (1200)
连续电流 (A)	8	16	12
峰值推力 (N)	3000	4500	6000
峰值电流 (A)	21	40	30
额定速度 (m/s)	1	1	1
最高速度 (m/s)	2.5	3	1.5
推力常数 (N/A)	150	112	200
相反电势常数 (Vs/m)	56	40	69
25℃相电阻 ( $\Omega$ )	3.46	1.41	2.43
120℃相电阻 ( $\Omega$ )	4.73	1.93	3.31
正向吸力 (N)	6800	10200	13600
冷却最小流量 (L/min)	2.5		
初级规格	134XJT1K2M10-00	134XJT1K8M10-00	134XJT2K4M10-00
初级重量 (kg)	12	17	22
绝缘等级	F (GB/T 755—2019/IEC 60034-1: 2017)		
防护等级	IP65 (GB/T 4208—2017/IEC 60529: 2013, GB/T 4942—2021/IEC 60034-5: 2020)		
次级规格	140XJTS4-01		
次级重量/件 (kg)	2.4 (单件长 184mm)		
精密冷却罩 (选配)	134XJT1K2-02	134XJT1K8-02	134XJT2K4-02
精密冷却罩重量 (kg)	0.9	1.3	1.7

注：括号内为不通水时连续推力指标。

推力—速度特性图 (F-n) (A: 连续工作区; B: 短时工作区)

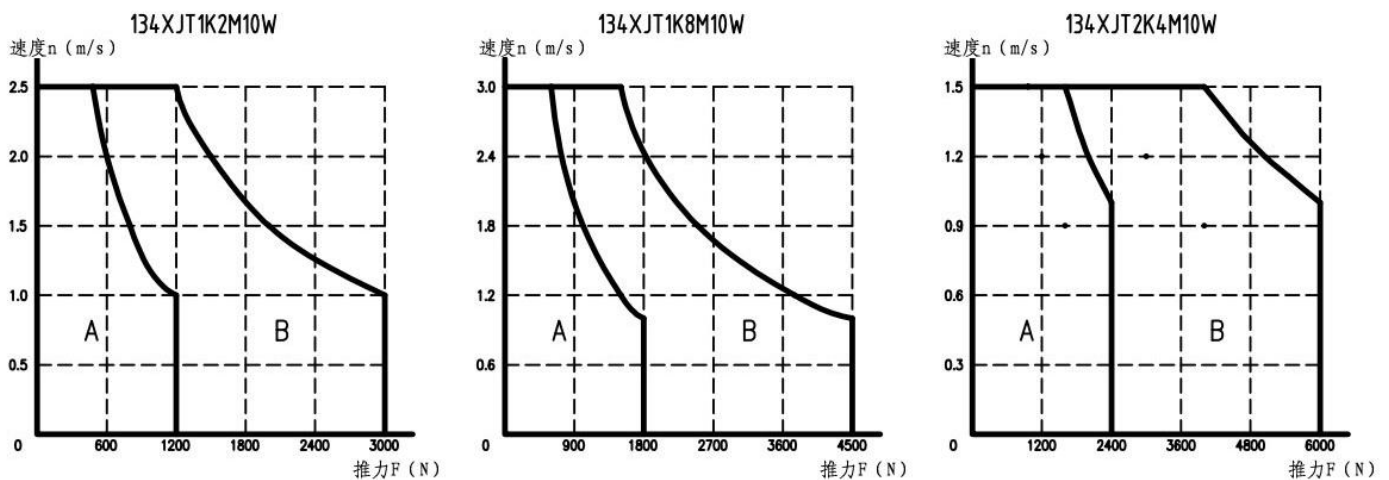

3.4 182XJT 系列直线电动机的主要技术参数

表 4

项目	型号		
	182XJT1K9L05W	182XJT2K8L05W	182XJT3K8L05W
额定功率 (kW)	0.95	1.4	1.9
极距 2τ (mm)	46		
驱动单元输入电压 (V)	单相 AC 220V		
连续推力 (N)	1900 (950)	2800 (1400)	3800 (1900)
连续电流 (A)	15	19	26
峰值推力 (N)	4750	7000	9500
峰值电流 (A)	38	48	65
额定速度 (m/s)	0.5	0.5	0.5
最高速度 (m/s)	1.5	1.5	1.5
推力常数 (N/A)	127	147	146
相反电势常数 (Vs/m)	66	51	51
25℃相电阻 (Ω)	1.41	1.1	0.7
120℃相电阻 (Ω)	1.92	1.53	0.97
正向吸力 (N)	10000	15000	20000
冷却最小流量 (L/min)	2.5		
初级规格	182XJT1K9L05-00	182XJT2K8L05-00	182XJT3K8L05-00
初级重量 (kg)	16	22	28
绝缘等级	F (GB/T 755-2019/IEC 60034-1: 2017)		
防护等级	IP65 (GB/T 4208-2017/IEC 60529: 2013, GB/T 4942-2021/IEC 60034-5: 2020)		
次级规格	188XJTS4-00		
次级重量/件 (kg)	3.8 (单件长 184mm)		
精密冷却罩 (选配)	182XJT1K9-02	182XJT2K8-02	182XJT3K8-02
精密冷却罩重量 (kg)	1.1	1.5	1.7

注：括号内为不通水时连续推力指标。

推力—速度特性图 (F-n) (A: 连续工作区; B: 短时工作区)

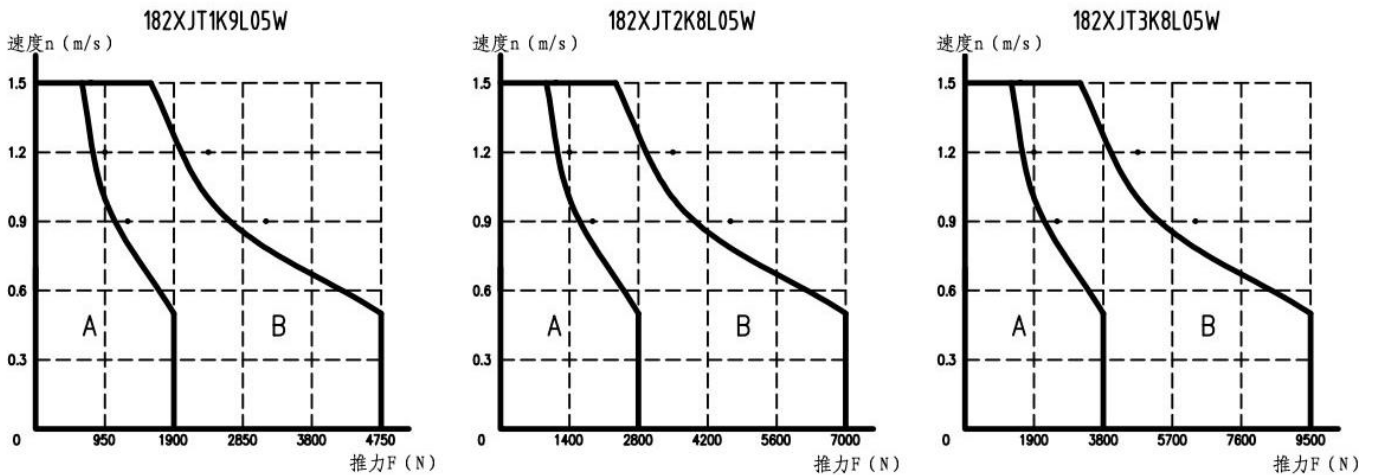

产品技术参数

表 4 (续)

项目	型号		
	182XJT1K9M05W	182XJT2K8M05W	182XJT3K8M05W
额定功率 (kW)	0.95	1.4	1.9
极距 $2\tau$ (mm)	46		
驱动单元输入电压 (V)	三相 AC 380V		
连续推力 (N)	1900 (950)	2800 (1400)	3800 (1900)
连续电流 (A)	9	14	15
峰值推力 (N)	4750	7000	9500
峰值电流 (A)	23	35	38
额定速度 (m/s)	0.5	0.5	0.5
最高速度 (m/s)	1.5	1.5	1.5
推力常数 (N/A)	212	200	253
相反电势常数 (Vs/m)	114	114	89
25℃相电阻 ( $\Omega$ )	4.37	3.03	2.0
120℃相电阻 ( $\Omega$ )	5.97	4.13	2.74
正向吸力 (N)	10000	15000	20000
冷却最小流量 (L/min)	2.5		
初级规格	182XJT1K9M05-00	182XJT2K8M05-00	182XJT3K8M05-00
初级重量 (kg)	16	22	28
绝缘等级	F (GB/T 755—2019/IEC 60034-1: 2017)		
防护等级	IP65 (GB/T 4208—2017/IEC 60529: 2013, GB/T 4942—2021/IEC 60034-5: 2020)		
次级规格	188XJTS4-00		
次级重量/件 (kg)	3.8 (单件长 184mm)		
精密冷却罩 (选配)	182XJT1K9-02	182XJT2K8-02	182XJT3K8-02
精密冷却罩重量 (kg)	1.1	1.5	1.7

注：括号内为不通水时连续推力指标。

推力—速度特性图 (F-n) (A: 连续工作区; B: 短时工作区)

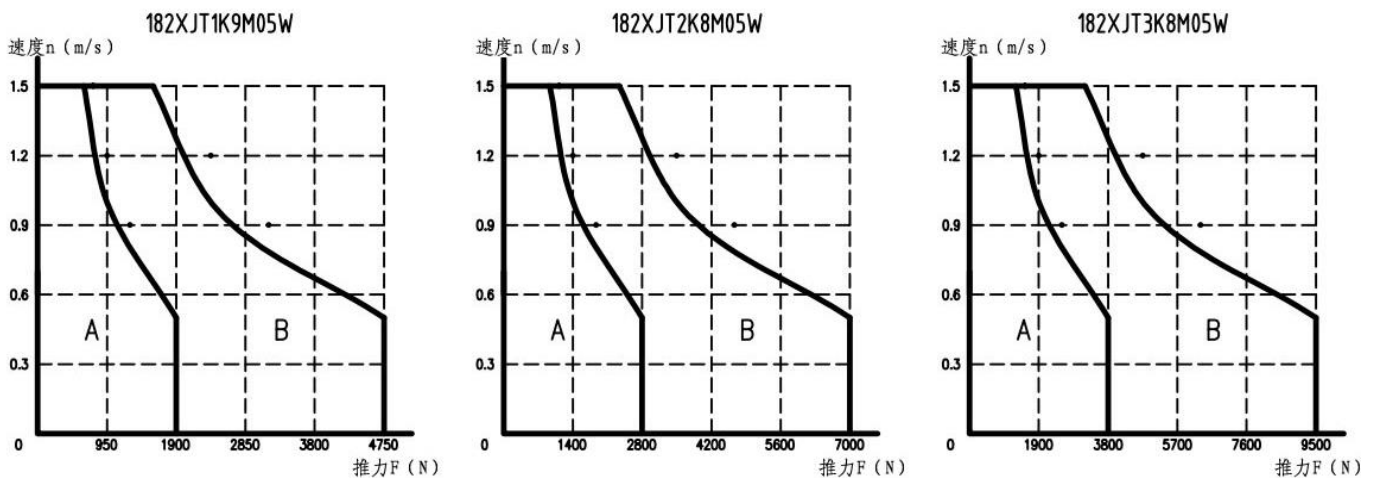

3.5 242XJT 系列直线电动机的主要技术参数

表 5

项目	型号		
	242XJT2K6L05W	242XJT2K6M05W	242XJT2K6M10W
额定功率 (kW)	1.3	1.3	2.6
极距 2τ (mm)	46		
驱动单元输入电压 (V)	单相 AC 220V	三相 AC 380V	
连续推力 (N)	2600 (1300)		
连续电流 (A)	20	12	15
峰值推力 (N)	6500	6500	6500
峰值电流 (A)	50	30	38
额定速度 (m/s)	0.5	0.5	1
最高速度 (m/s)	1.5	1.5	2
推力常数 (N/A)	130	217	173
相反电势常数 (Vs/m)	46	77	61
25℃相电阻 (Ω)	1.24	3.79	2.32
120℃相电阻 (Ω)	1.69	5.17	3.16
正向吸力 (N)	13700		
冷却最小流量 (L/min)	2.5		
初级规格	242XJT2K6L05-00	242XJT2K6M05-00	242XJT2K6M10-00
初级重量 (kg)	21	21	21
绝缘等级	F (GB/T 755-2019/IEC 60034-1: 2017)		
防护等级	IP65 (GB/T 4208-2017/IEC 60529: 2013, GB/T 4942-2021/IEC 60034-5: 2020)		
次级规格	248XJTS4-00		
次级重量/件 (kg)	4.6 (单件长 184mm)		
精密冷却罩 (选配)	242XJT2K6-02		
精密冷却罩重量 (kg)	1.2		

注：括号内为不通水时连续推力指标。

推力—速度特性图 (F-n) (A: 连续工作区; B: 短时工作区)



表 5 (续)

项目	型号	
	242XJT3K9M05W	242XJT3K9M10W
额定功率 (kW)	1.95	3.9
极距 $2\tau$ (mm)	46	
驱动单元输入电压 (V)	三相 AC 380V	
连续推力 (N)	3900 (1950)	3900 (1950)
连续电流 (A)	14	18
峰值推力 (N)	9750	9750
峰值电流 (A)	35	45
额定速度 (m/s)	0.5	1
最高速度 (m/s)	1	1.5
推力常数 (N/A)	279	217
相反电势常数 (Vs/m)	97	75
25℃相电阻 ( $\Omega$ )	3.81	2.24
120℃相电阻 ( $\Omega$ )	5.2	3.06
正向吸力 (N)	20550	
冷却最小流量 (L/min)	2.5	
初级规格	242XJT3K9M05-00	242XJT3K9M10-00
初级重量 (kg)	29	29
绝缘等级	F (GB/T 755—2019/IEC 60034-1: 2017)	
防护等级	IP65 (GB/T 4208—2017/IEC 60529: 2013, GB/T 4942—2021/IEC 60034-5: 2020)	
次级规格	248XJTS4-00	
次级重量/件 (kg)	4.6 (单件长 184mm)	
精密冷却罩 (选配)	242XJT3K9-02	
精密冷却罩重量 (kg)	1.7	

注：括号内为不通水时连续推力指标。

推力—速度特性图 (F-n) (A: 连续工作区; B: 短时工作区)

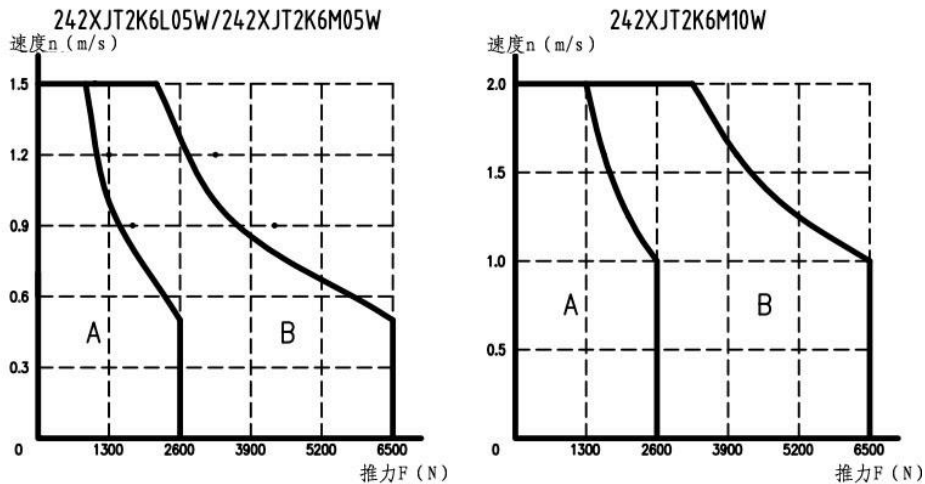
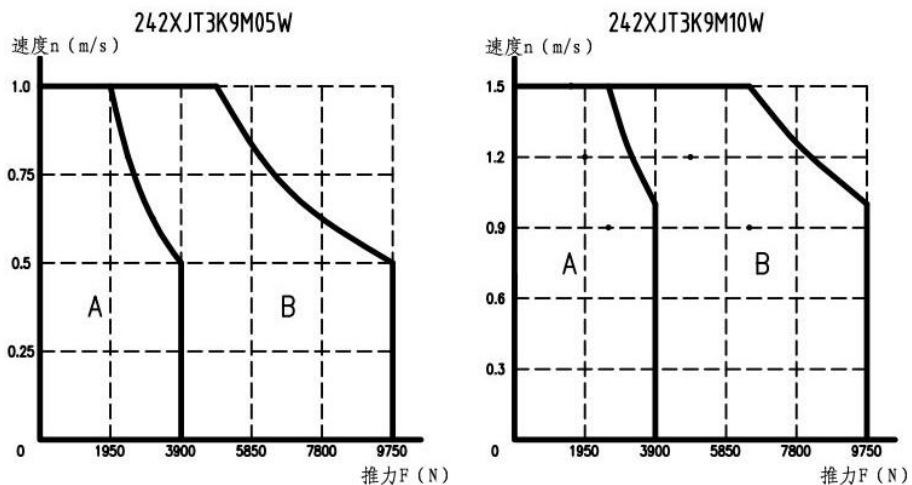

3.6 334XJT 系列直线电动机的主要技术参数

表 6

项目	型号	
	334XJT04KM05W	334XJT04KM10W
额定功率 (kW)	2	4
极距 $2\tau$ (mm)	46	
驱动单元输入电压 (V)	三相 AC 380V	
连续推力 (N)	4000 (2000)	4000 (2000)
连续电流 (A)	15	20
峰值推力 (N)	10000	10000
峰值电流 (A)	38	50
额定速度 (m/s)	0.5	1
最高速度 (m/s)	1	1.5
推力常数 (N/A)	267	200
相反电势常数 (Vs/m)	93	68
25°C相电阻 ( $\Omega$ )	3.88	2.02
120°C相电阻 ( $\Omega$ )	5.3	2.75
正向吸力 (N)	20000	
冷却最小流量 (L/min)	2.5	
初级规格	334XJT04KM05-00	334XJT04KM10-00
初级重量 (kg)	26	26
绝缘等级	F (GB/T 755—2019/IEC 60034-1: 2017)	
防护等级	IP65 (GB/T 4208—2017/IEC 60529: 2013, GB/T 4942—2021/IEC 60034-5: 2020)	
次级规格	340XJTS4-00	
次级重量/件 (kg)	7.5 (单件长 184mm)	
精密冷却罩 (选配)	334XJT04K-02	
精密冷却罩重量 (kg)	1.4	

注：括号内为不通水时连续推力指标。

推力—速度特性图 (F-n) (A: 连续工作区; B: 短时工作区)





表 6 (续)

项目	型号	
	334XJT06KM05W	334XJT06KM10W
额定功率 (kW)	3	6
极距 $2\tau$ (mm)	46	
驱动单元输入电压 (V)	三相 AC 380V	
连续推力 (N)	6000 (3000)	6000 (3000)
连续电流 (A)	23	30
峰值推力 (N)	15000	15000
峰值电流 (A)	58	75
额定速度 (m/s)	0.5	1
最高速度 (m/s)	1	1.5
推力常数 (N/A)	261	200
相反电势常数 (Vs/m)	92	69
25℃相电阻 ( $\Omega$ )	2.56	1.36
120℃相电阻 ( $\Omega$ )	3.5	1.86
正向吸力 (N)	30000	
冷却最小流量 (L/min)	2.5	
初级规格	334XJT06KM05-00	334XJT06KM10-00
初级重量 (kg)	39	39
绝缘等级	F (GB/T 755—2019/IEC 60034-1: 2017)	
防护等级	IP65 (GB/T 4208—2017/IEC 60529: 2013, GB/T 4942—2021/IEC 60034-5: 2020)	
次级规格	340XJTS4-00	
次级重量/件 (kg)	7.5 (单件长 184mm)	
精密冷却罩 (选配)	334XJT06K-02	
精密冷却罩重量 (kg)	1.9	

注：括号内为不通水时连续推力指标。

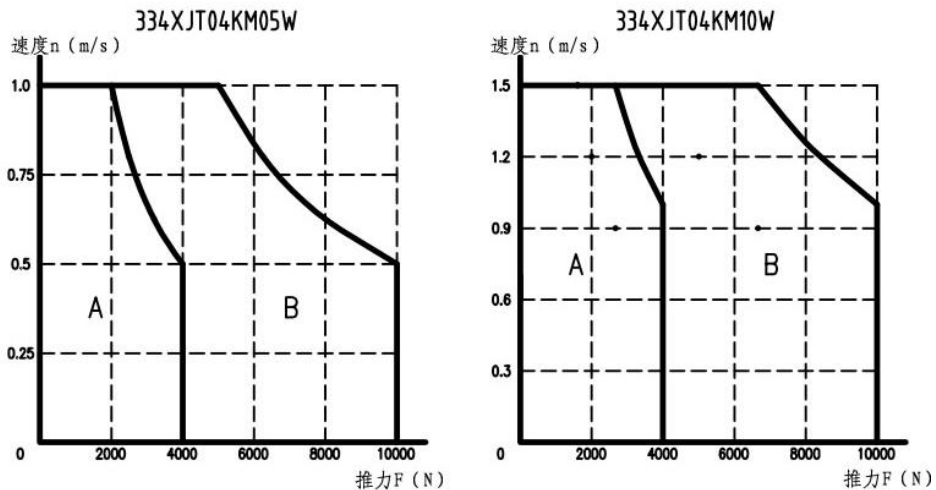
推力—速度特性图 (F-n) (A: 连续工作区; B: 短时工作区)

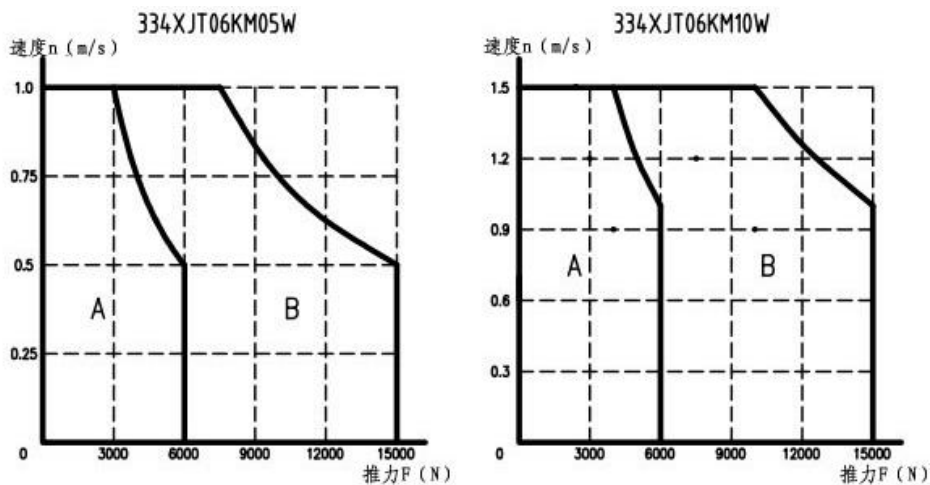

3.7 340XJT 系列直线电动机的主要技术参数

表 7

项目	型号	
	340XJT08KM05W	340XJT08KM10W
额定功率 (kW)	4	8
极距 $2\tau$ (mm)	46	
驱动单元输入电压 (V)	三相 AC 380V	
连续推力 (N)	8000 (4000)	8000 (4000)
连续电流 (A)	30	40
峰值推力 (N)	20000	20000
峰值电流 (A)	75	100
额定速度 (m/s)	0.5	1
最高速度 (m/s)	1	1.5
推力常数 (N/A)	267	200
相反电势常数 (Vs/m)	90	69
25°C相电阻 ( $\Omega$ )	1.74	1.02
120°C相电阻 ( $\Omega$ )	2.38	1.39
正向吸力 (N)	40000	
冷却最小流量 (L/min)	2.5	
初级规格	340XJT08KM05-00	334XJT08KM10-00
初级重量 (kg)	51	51
绝缘等级	F (GB/T 755—2019/IEC 60034-1: 2017)	
防护等级	IP65 (GB/T 4208—2017/IEC 60529: 2013, GB/T 4942—2021/IEC 60034-5: 2020)	
次级规格	340XJTS4-00	
次级重量/件 (kg)	7.5 (单件长 184mm)	
精密冷却罩 (选配)	340XJT08K-02	
精密冷却罩重量 (kg)	2.4	

注：括号内为不通水时连续推力指标。

推力—速度特性图 (F-n) (A: 连续工作区; B: 短时工作区)

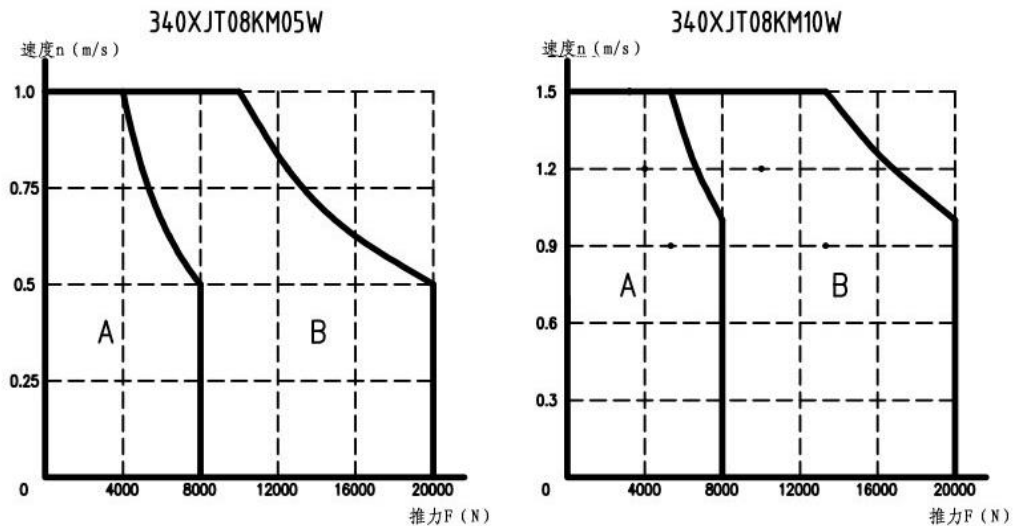

## 4 外形及安装尺寸

### 4.1 88XJT 系列直线电动机外形及安装尺寸



图 1

### 4.2 100XJT 系列直线电动机外形及安装尺寸

带精密冷却罩

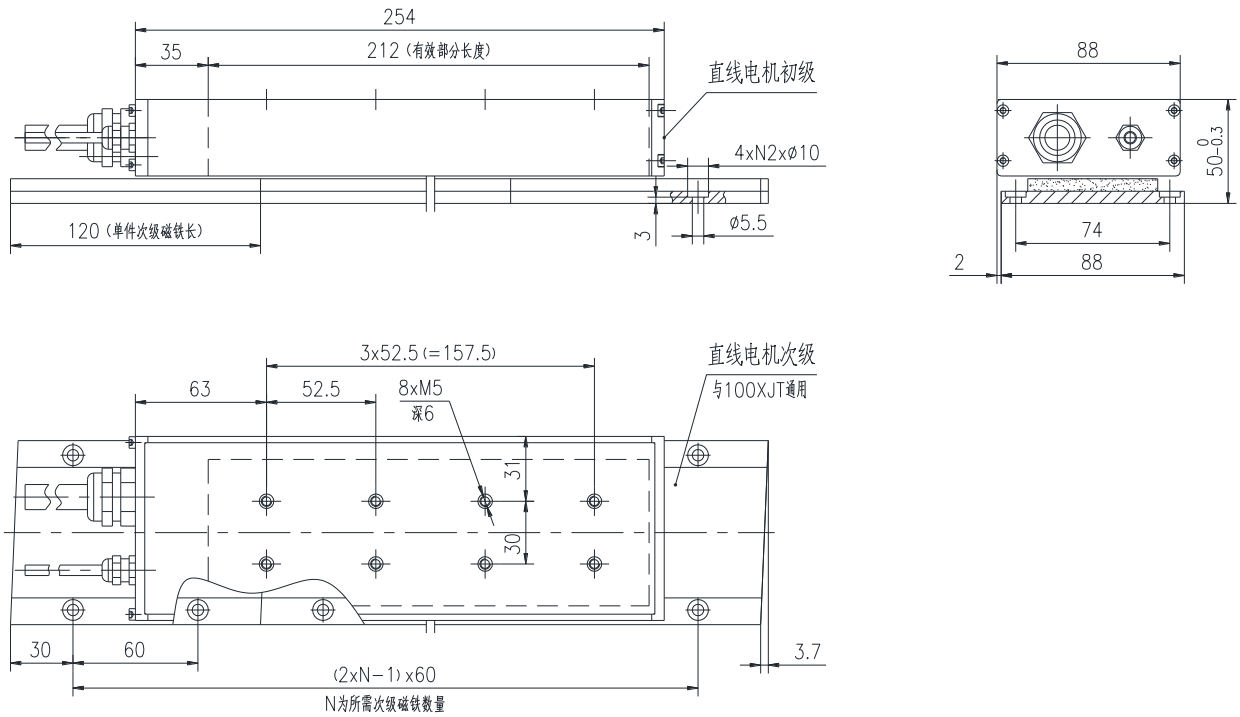

图 2

规格尺寸:

100XJT	400	600
L	254	359
N1	1	3
L1	52.5	157.5
N2	次级磁铁数量(根据实际行程定)	

不带精密冷却罩

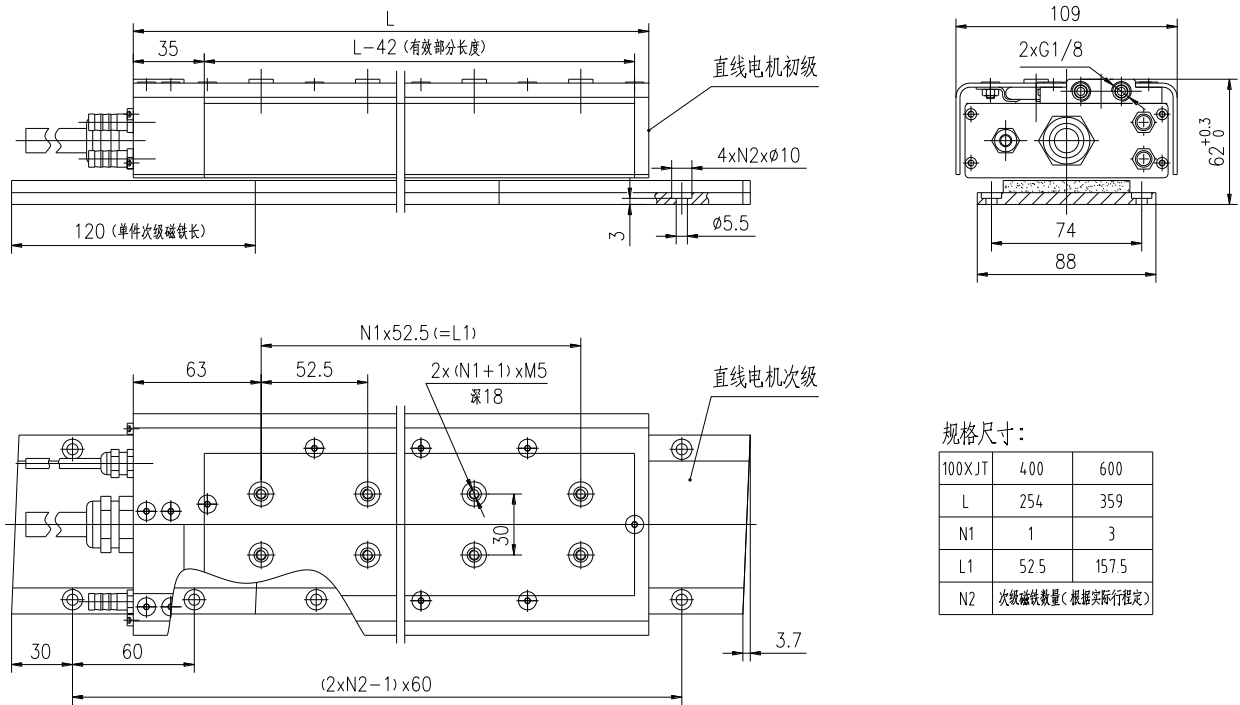

图 3

### 4.3 134XJT 系列直线电动机外形及安装尺寸

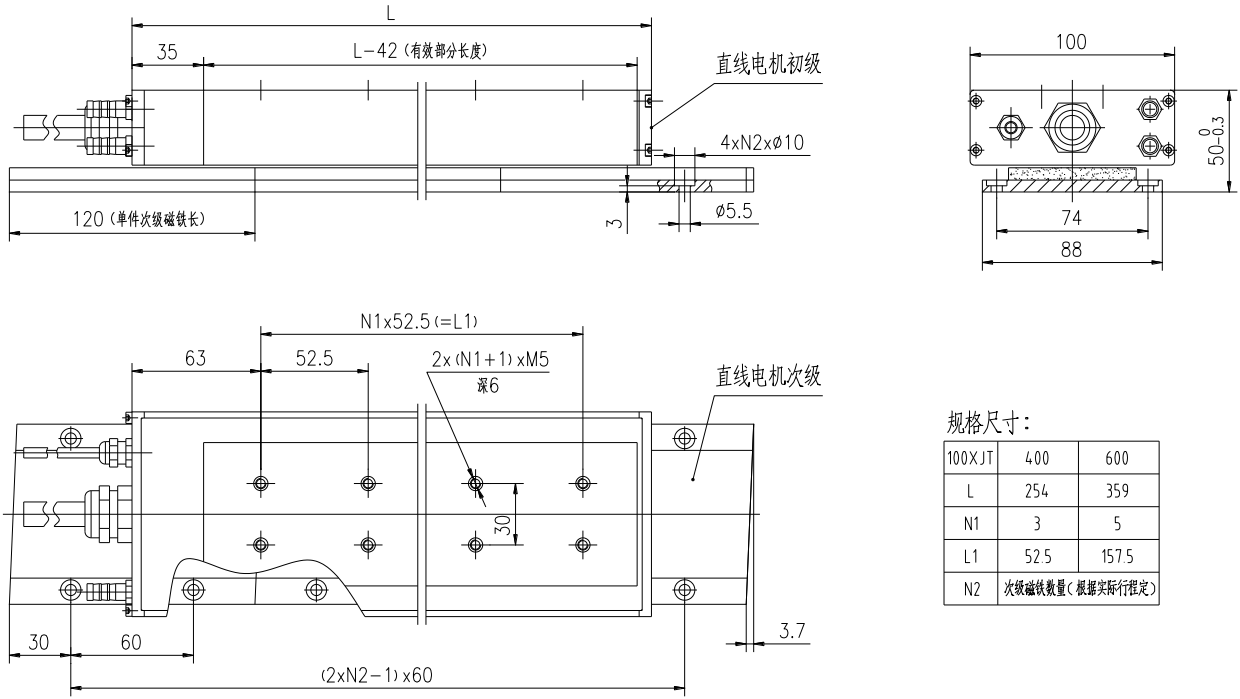

图 4

## 外形及安装尺寸

不带精密冷却罩

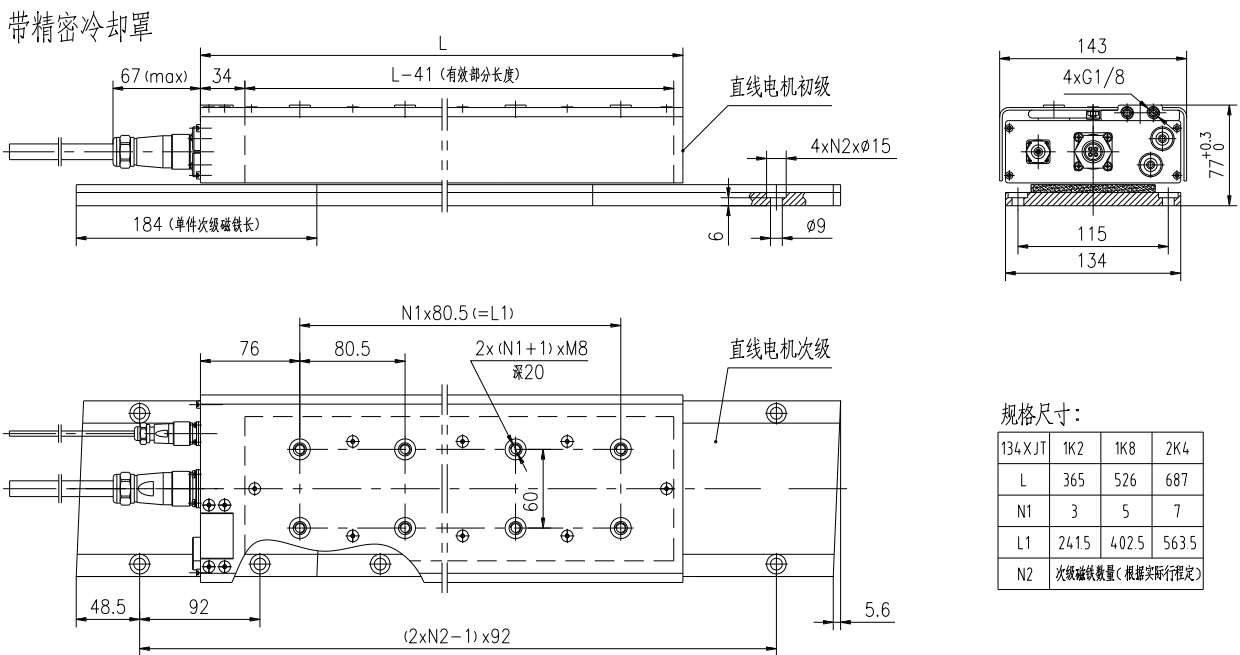

图 5

### 4.4 182XJT 系列直线电动机外形及安装尺寸

带精密冷却罩

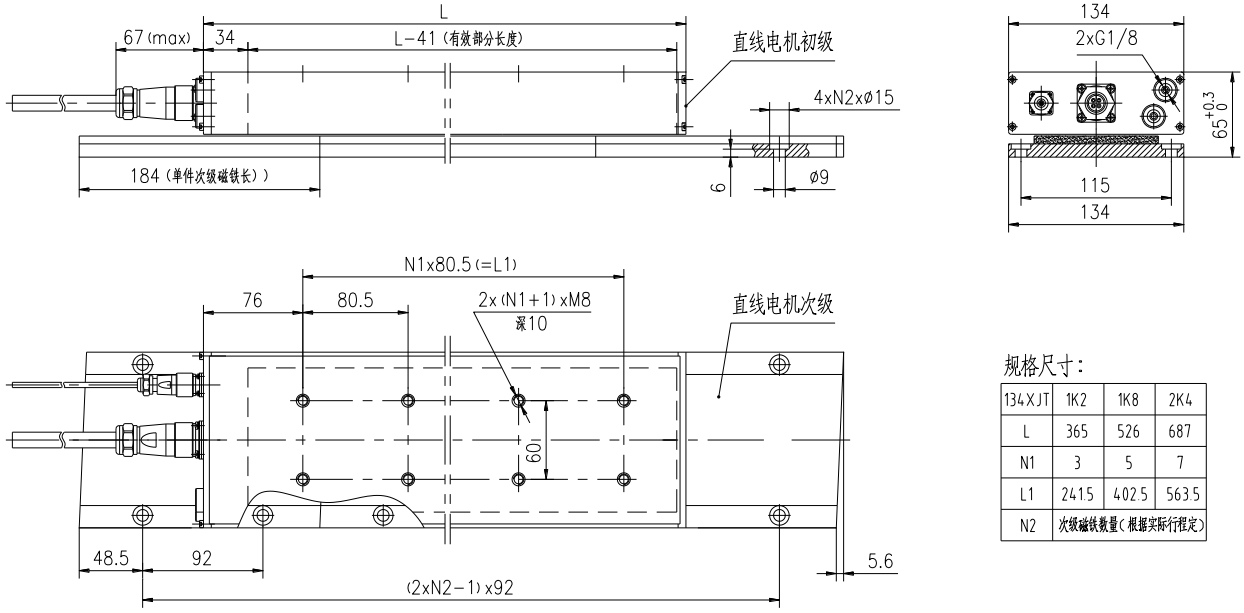

图 6



图 7

#### 4.5 242XJT 系列直线电动机外形及安装尺寸

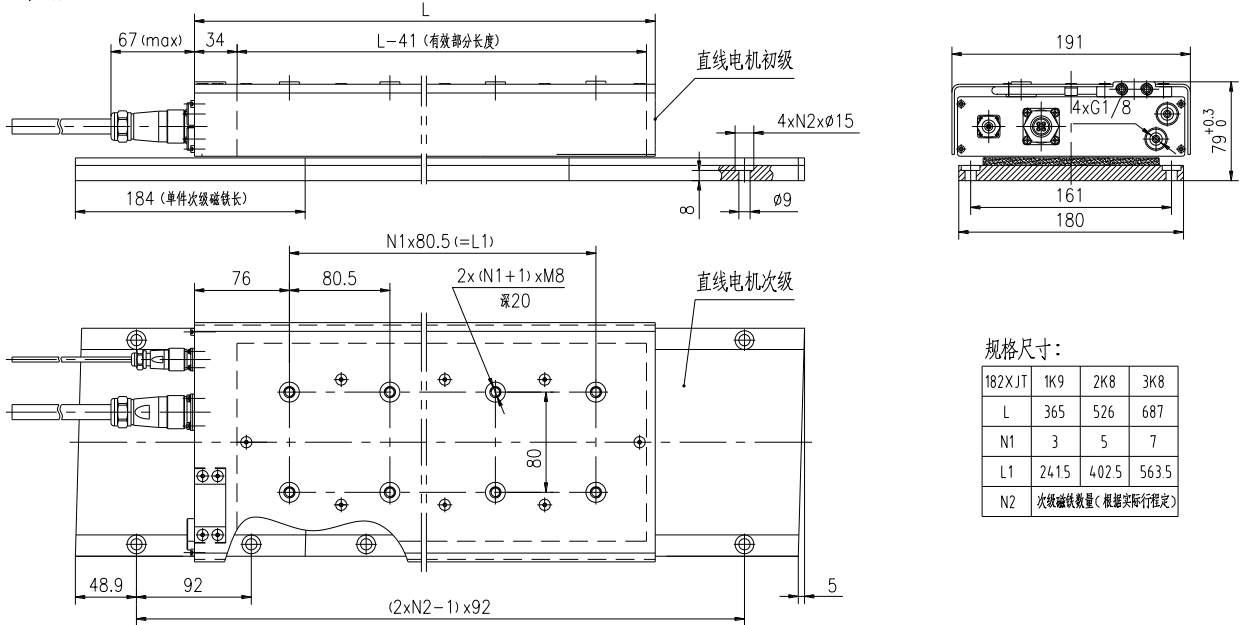

图 8

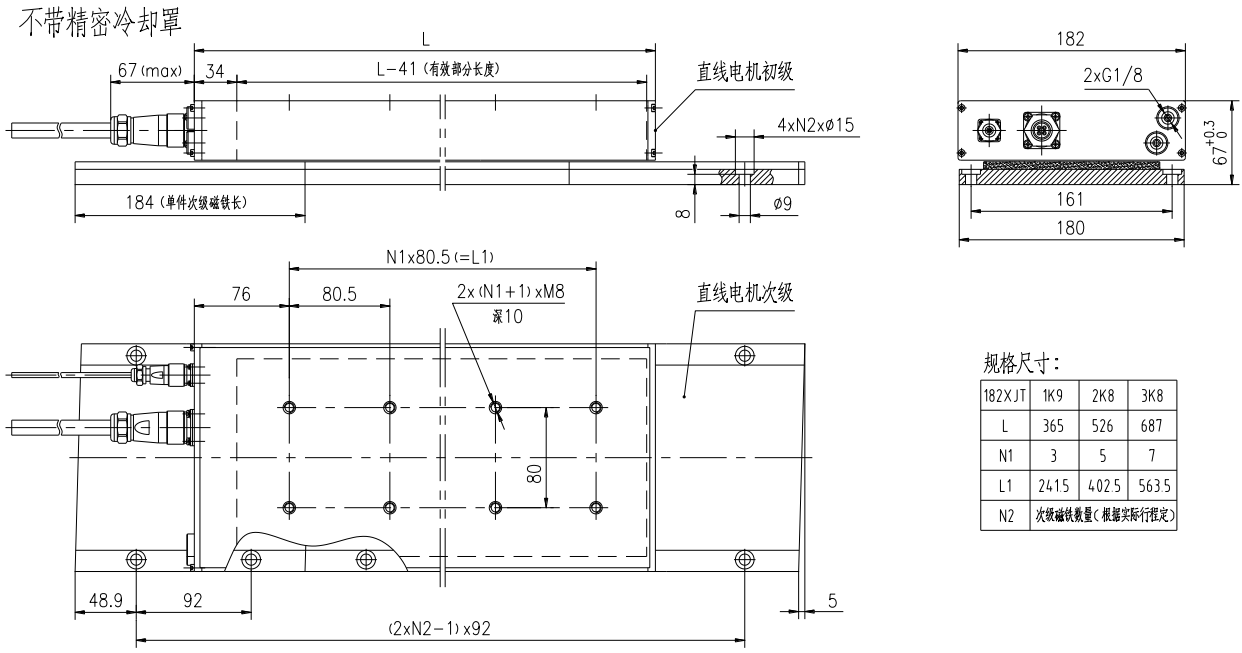
## 外形及安装尺寸

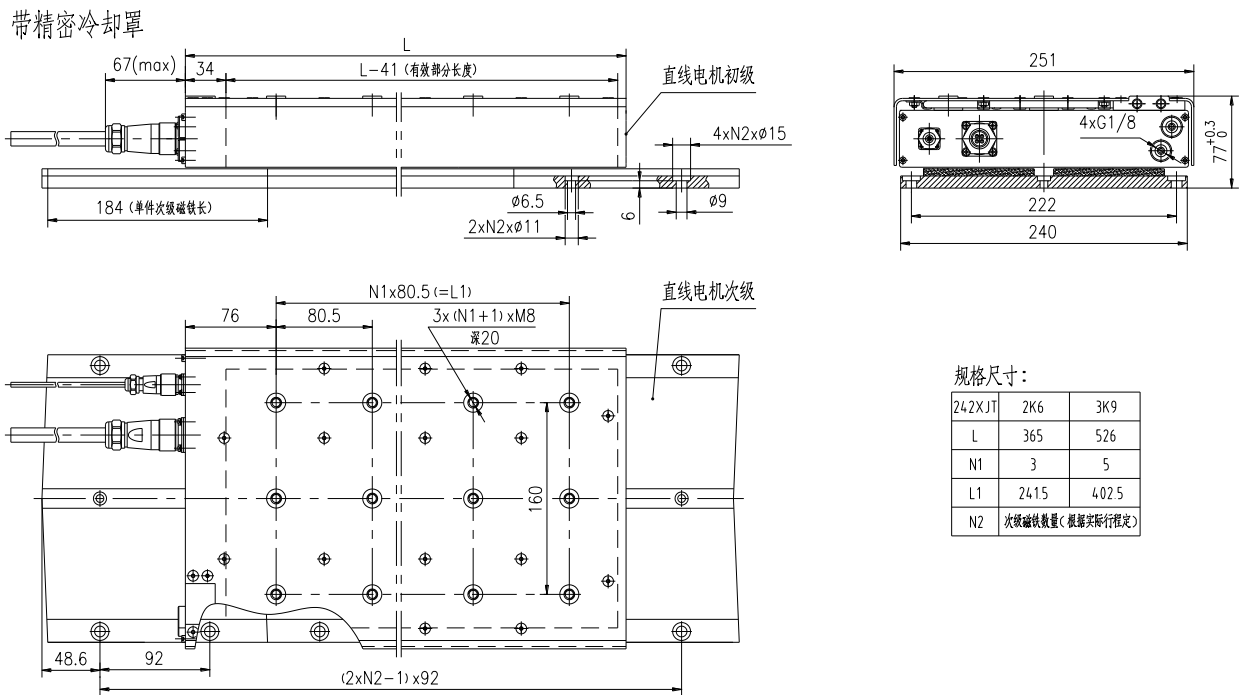

图 9

### 4.6 334XJT 系列直线电动机外形及安装尺寸



图 10

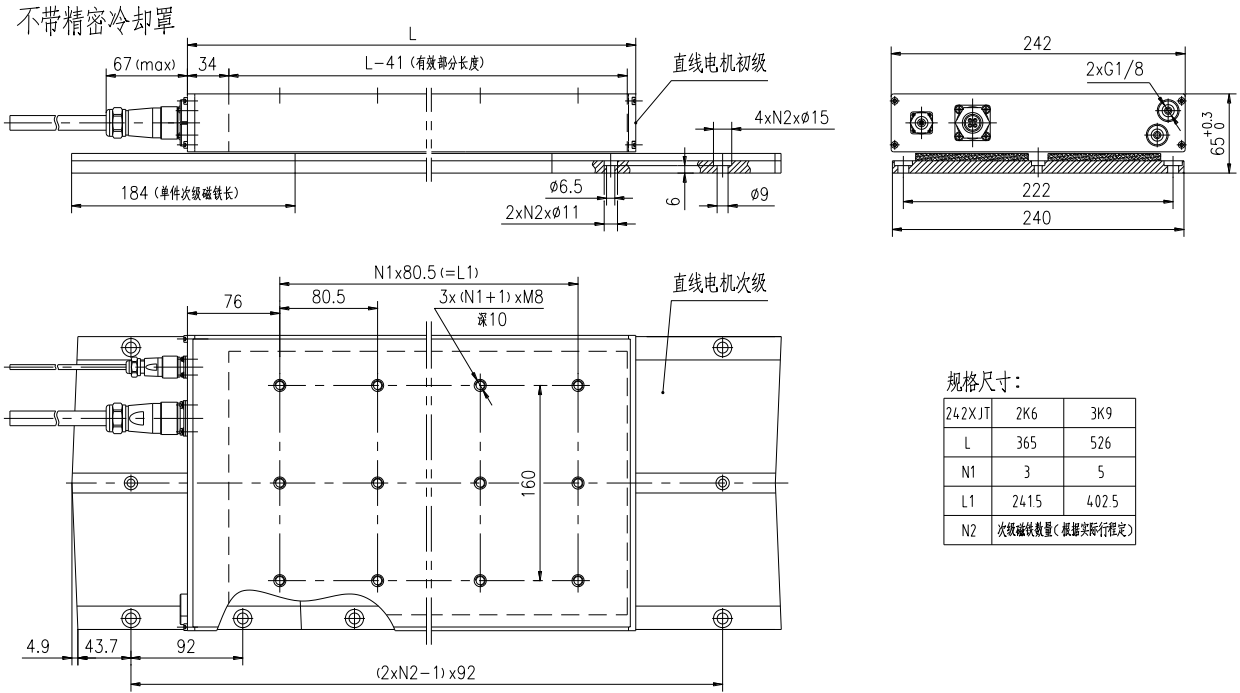

图 11

4.7 340XJT 系列直线电动机外形及安装尺寸

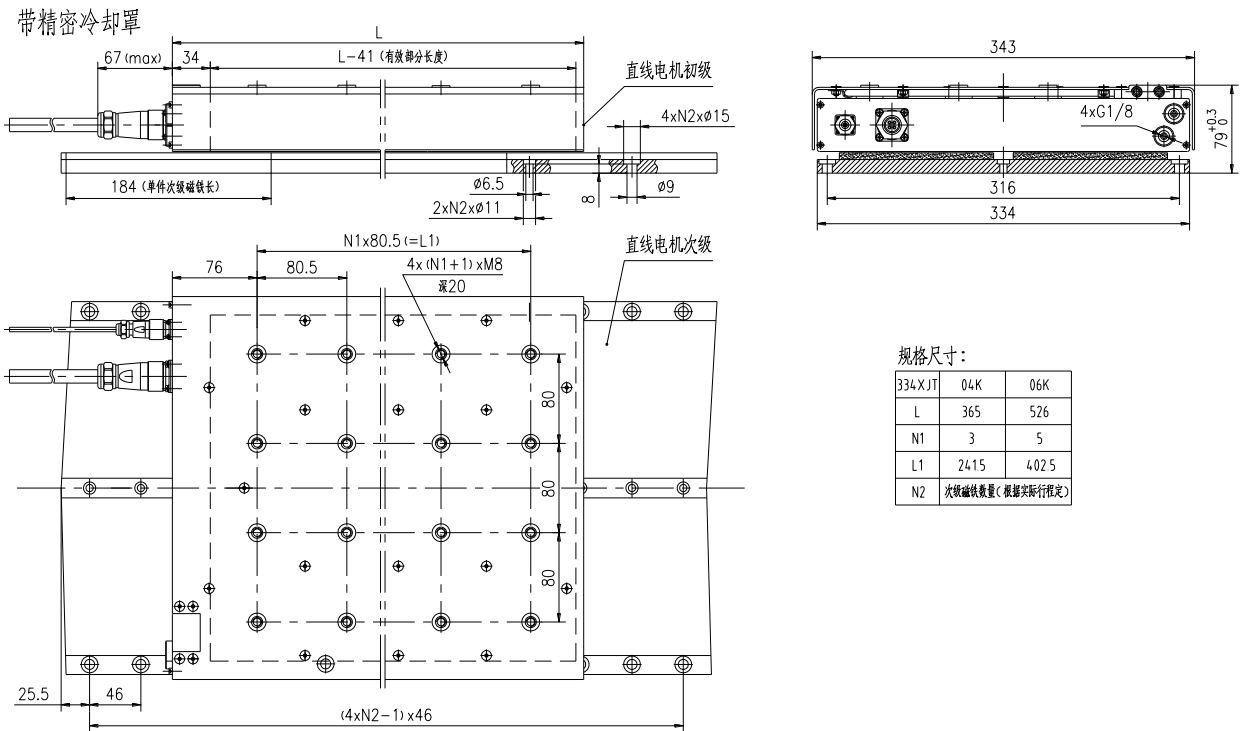

图 12

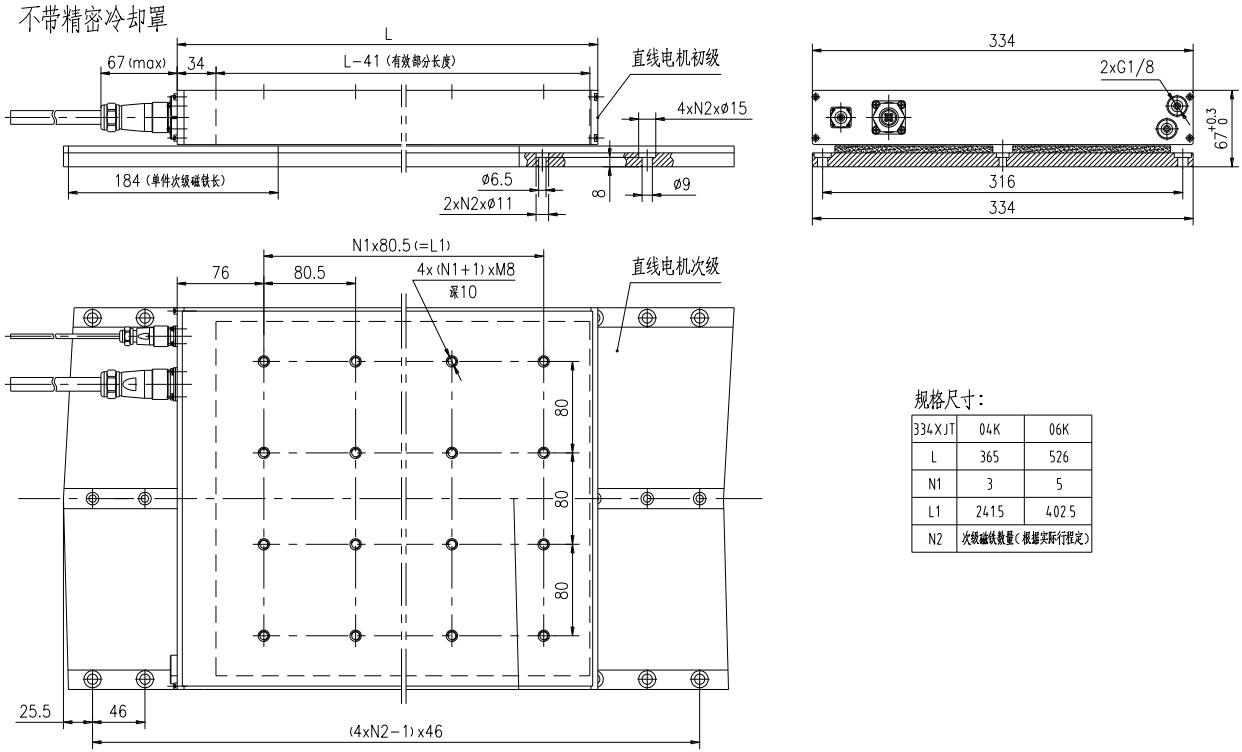

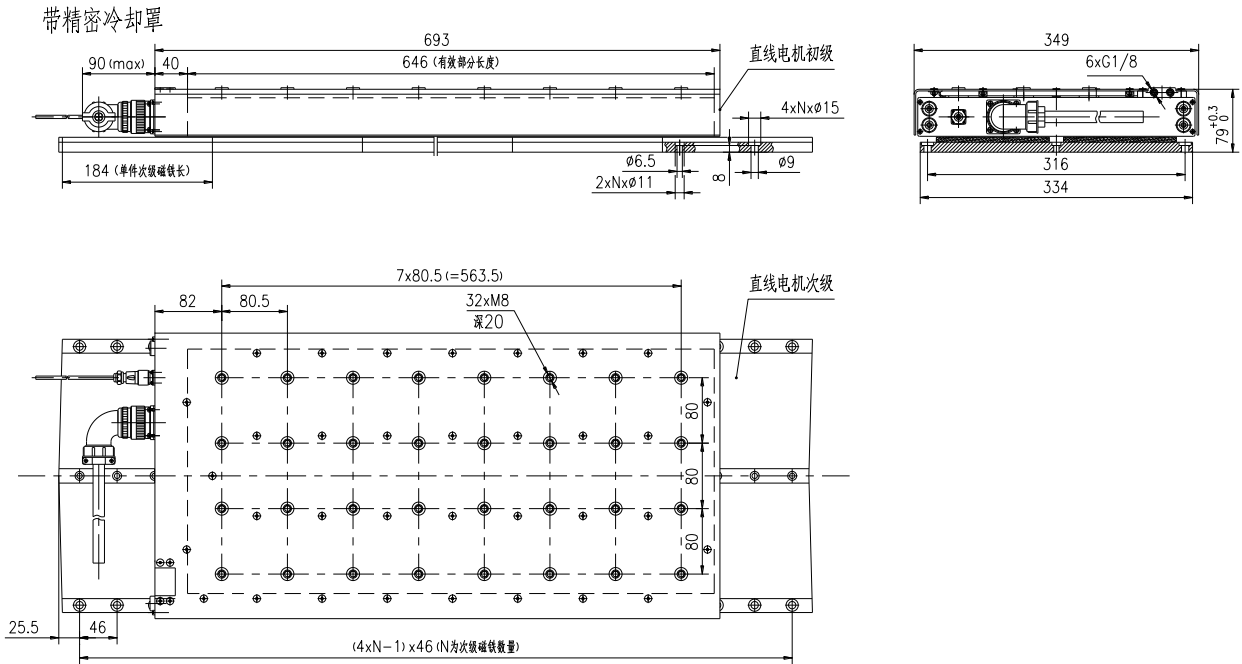

图 13

## 5 安装要求及注意事项

### 5.1 直线电动机组成

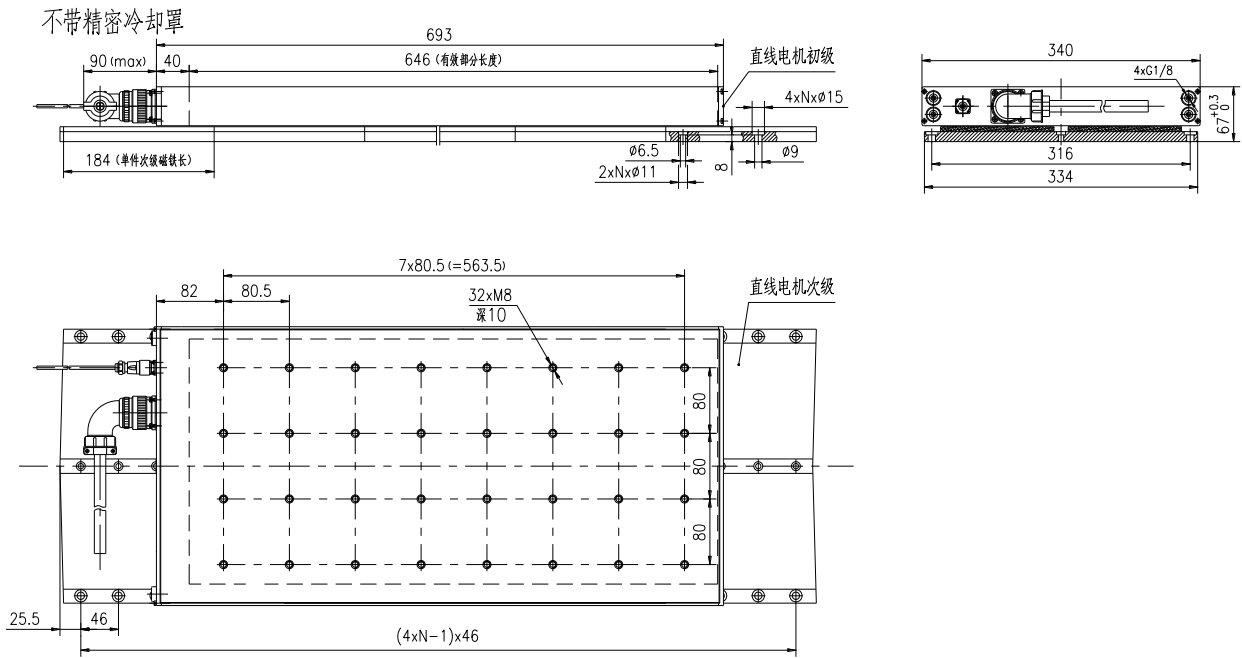

图 14

永磁同步直线电动机主要为初级组件和次级组件组合而成。

**初级组件：**主要为直线电动机绕组、测温元件及内部冷却组件。

**次级组件：**次级为永磁体即磁钢，用于直线电动机励磁。

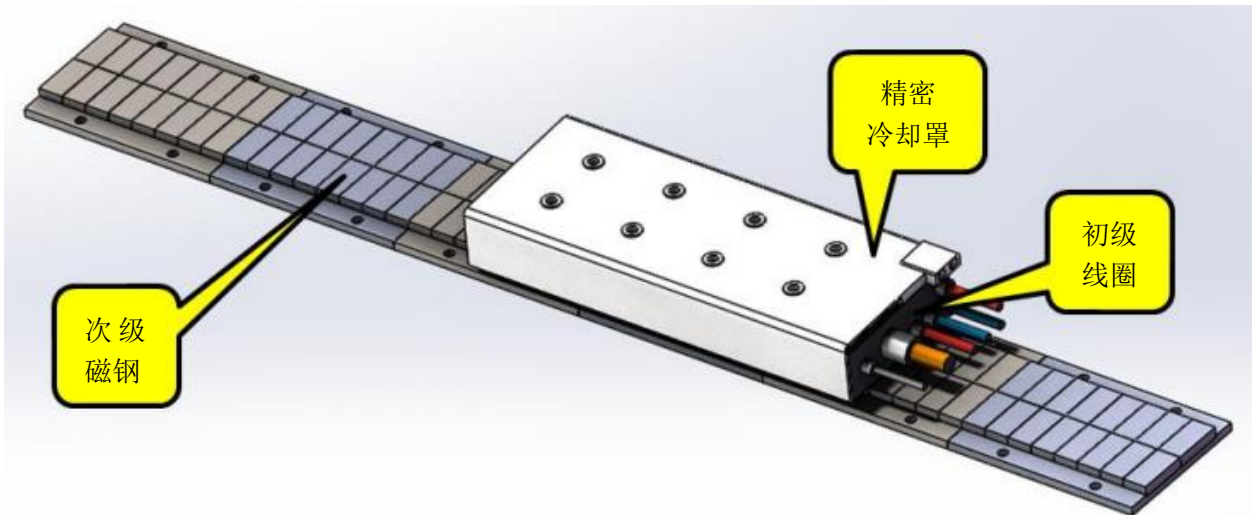
其为多块拼接组合结构，具体长度根据行程所需确定。

**精密冷却罩：**冷却罩为选配件，为隔绝直线电动机热量传导至工作台面而影响到加工精度。

### 5.2 安装结构

直线电动机安装使用时，除了基础的底座、拖板及导轨外，必须包含线性编码器以及必要的防撞装置。布局如图 15 所示。



图 15

**线性编码器：**直线电动机控制中不可或缺的组成部分，是运行控制和位置检测与反馈的关键部件。目前常用的有：光栅尺和磁栅尺。通常由客户自备，根据使用需求选择。目前本公司可适配海德汉 Endat 协议绝对式光栅尺、法格 SSI 协议绝对式光栅、意大利 GIVI 和长春禹衡 BiSS (C)协议绝对式光栅尺等。

**防撞装置：**为防止调试运行时的误操作或其他意外情况，避免或减小机械部件（特别是线性编码器）的损坏。

### 5.3 安装要求

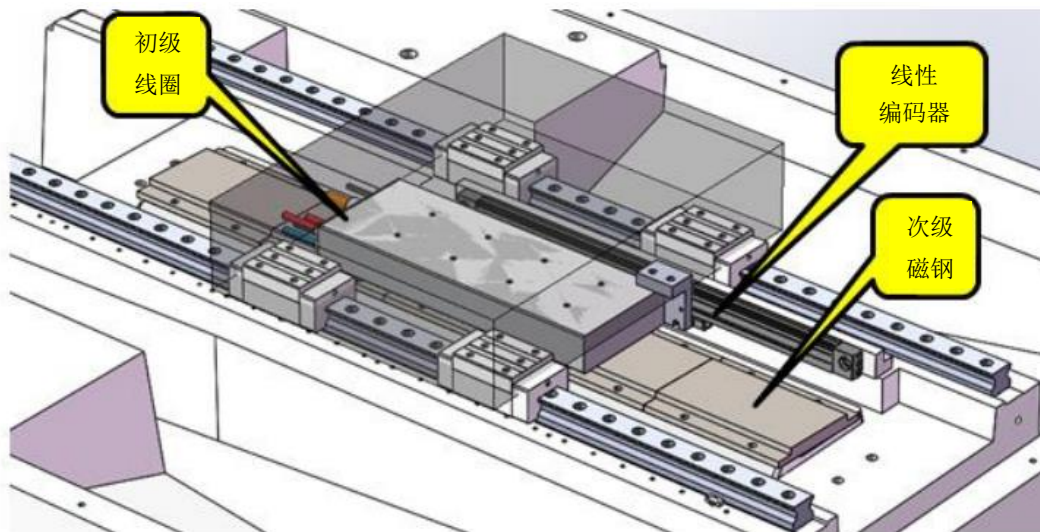
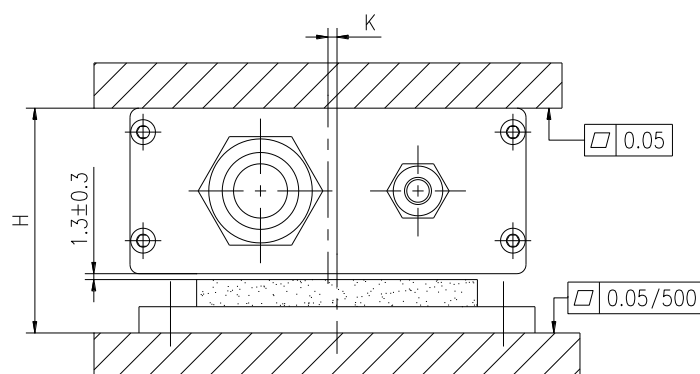

XJT 系列		型号						
尺寸 (mm)		88XJT	100XJT	134XJT	182XJT	242XJT	334XJT	340XJT
组合高度H	不带精密冷却罩	50 <sup>0</sup> <sub>-0.3</sub>	50 <sup>0</sup> <sub>-0.3</sub>	65 <sup>+0.3</sup> <sub>0</sub>	67 <sup>+0.3</sup> <sub>0</sub>	65 <sup>+0.3</sup> <sub>0</sub>	67 <sup>+0.3</sup> <sub>0</sub>	67 <sup>+0.3</sup> <sub>0</sub>
	带精密冷却罩	/	62 <sup>+0.3</sup> <sub>0</sub>	77 <sup>+0.3</sup> <sub>0</sub>	79 <sup>+0.3</sup> <sub>0</sub>	77 <sup>+0.3</sup> <sub>0</sub>	79 <sup>+0.3</sup> <sub>0</sub>	79 <sup>+0.3</sup> <sub>0</sub>
中心线偏差K		2±1	0±1					

图 16

注：为避免中心线偏移过大导致单边磁拉力不平衡而引起振动，除 88XJT 为特意偏移 2mm 外，其余规格皆需控制在 1mm 以内。

#### 5.4 安装顺序

通常情况下，先安装初级组件和精密冷却罩（选配），再安装次级组件。次级组件采用分段安装法，先将滑板推向一边，在露出部分安装次级组件，装完后再推向另一端，安装另一端的次级组件，如图 17 所示。

注：推动初级组件时请确保 U、V、W 三相电缆无短接，否则会无法推动。



图 17

#### 5.5 气隙对连续推力的影响

直线电动机的推力百分比见表 8 和图 18。

表 8

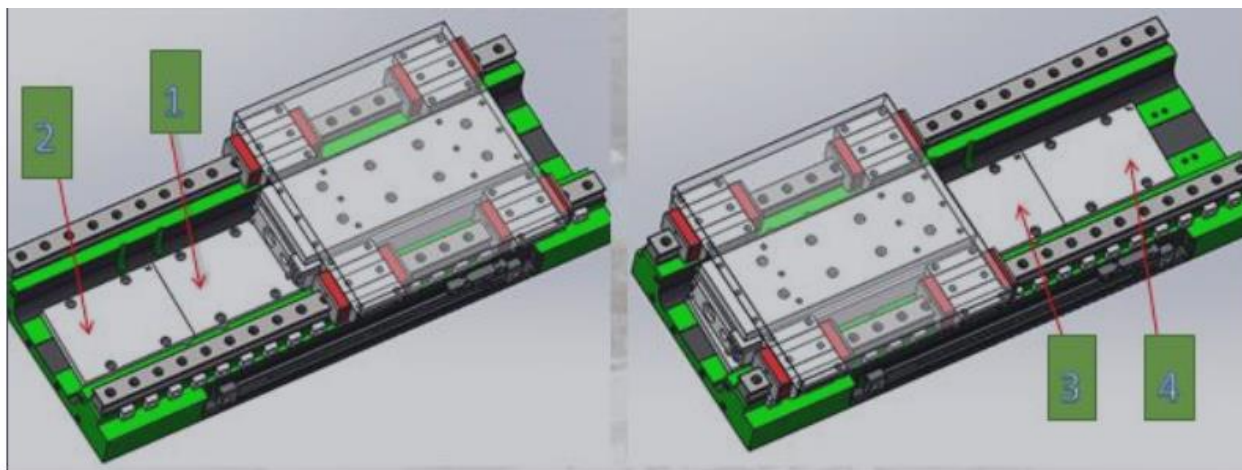
气隙 $\delta$	型号				
	88XJT/100XJT	134XJT	182XJT	242XJT	334XJT/340XJT
1.0	106.60%	105.10%	105.41%	105.37%	105.35%
1.1	104.30%	103.33%	103.53%	103.45%	103.48%
1.2	102.13%	101.61%	101.70%	101.67%	101.68%
1.3	100.00%	100.00%	100.00%	100.00%	100.00%
1.4	97.83%	98.33%	98.28%	98.29%	98.28%
1.5	95.79%	96.73%	96.59%	96.65%	96.61%
1.6	93.75%	95.22%	95.02%	95.10%	95.07%



图 18

5.5 并联使用

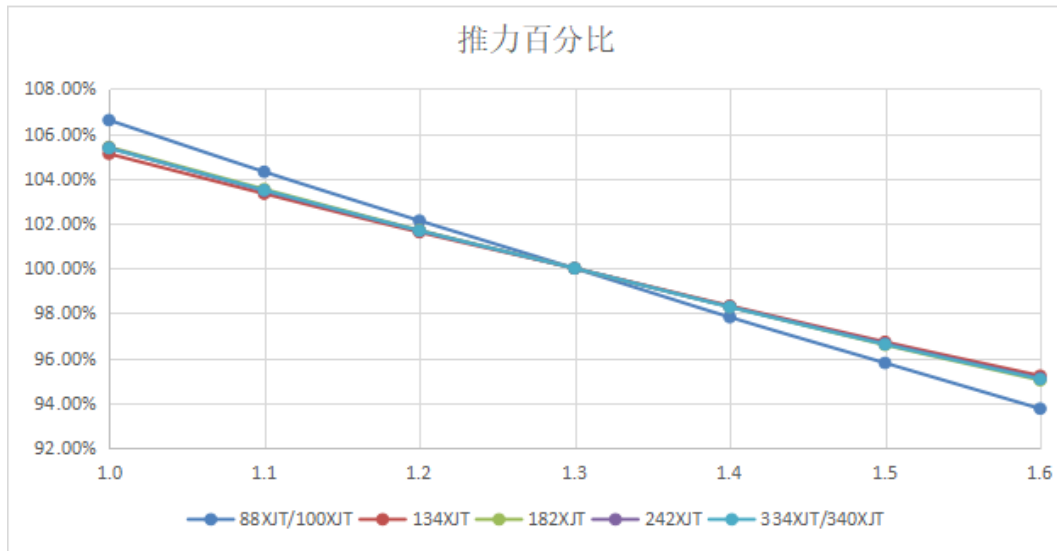

图 19

表 9

相序		出线同侧			出线朝外			出线朝内		
直线电动机 1		U	V	W	U	V	W	U	V	W
直线电动机 2		U	V	W	W	V	U	W	V	U
间隔 $\Delta x$ (mm)	极距 $2\tau=30\text{mm}$	$\geq 180$			$\geq 90$			$\geq 330$		
	极距 $2\tau=46\text{mm}$	$\geq 230$			$\geq 138$			$\geq 414$		

## 5.6 其他安装注意事项

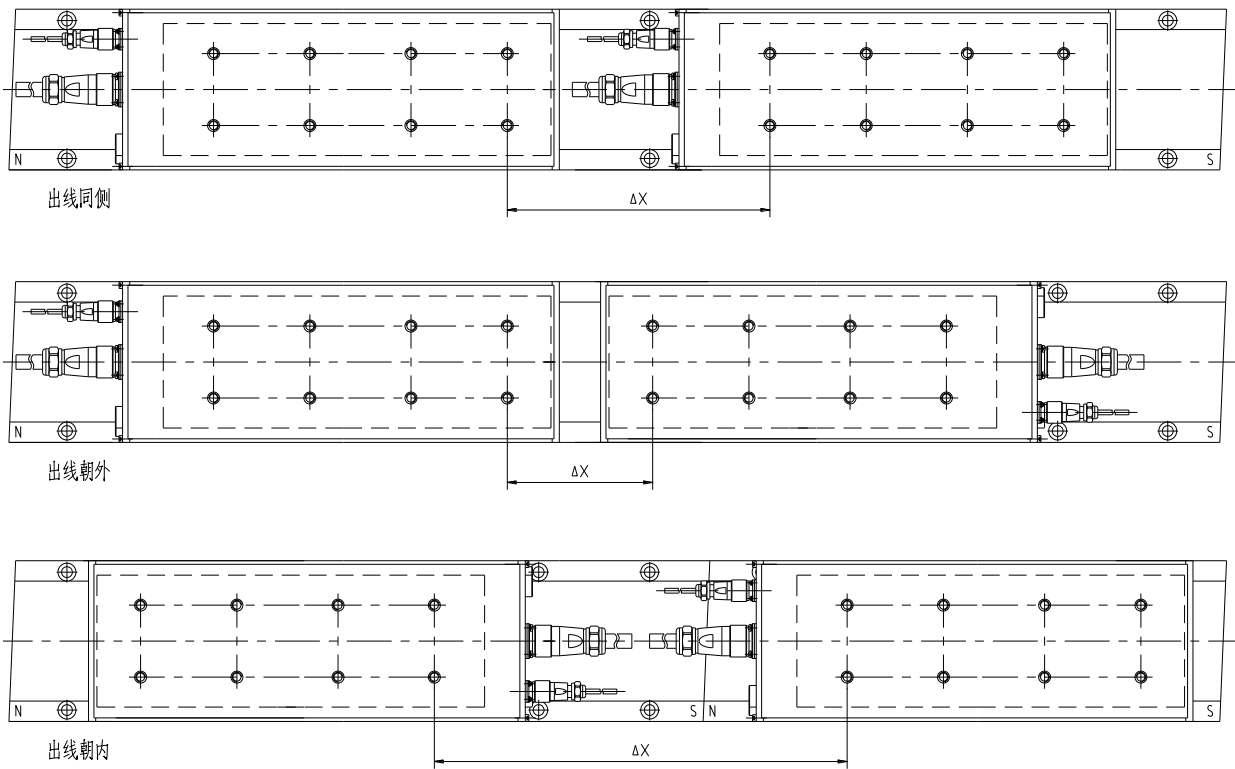
5.6.1 直线电动机初级和次级组件之间存在较大的正向吸力，一般为直线电动机连续推力的5~6倍，故导轨选型和滑座设计时，应考虑足够的刚度和强度。另外，为提高运动轴的动特性，应尽量将机械重心置于直线电动机宽度范围内，如图20所示。



图 20

5.6.2 直线电动机应用于垂直或倾斜轴时，在无使能状态，由于重力作用直线电动机会掉落，故需设计平衡和刹车装置。（具体平衡和刹车装置选用请参考《GSK XJT 系列永磁同步直线电动机应用指南》）

## 6 直线电动机选型

### 6.1 直线电动机的选型计算方法

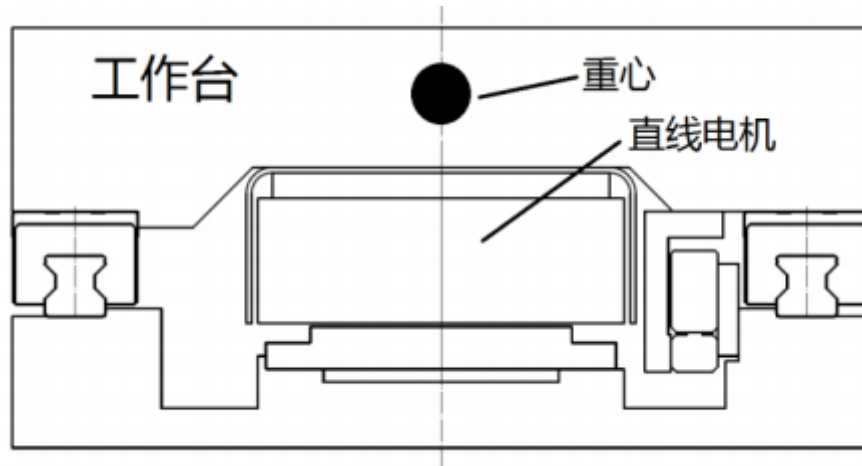
直线电动机的选型计算与旋转电动机存在较大差异，其步骤通常如下：

- 1) 结合机床结构，预估直线电动机安装空间，对直线电动机框架号进行限定；
- 2) 根据机床移动部件重量、运行速度及加速度等指标，对直线电动机进行预选定；
- 3) 根据预选定直线电动机参数复核，最终确定直线电动机型号规格。

计算方式较为复杂，可先确定机械参数，填入本公司提供的选型分析表格进行核实，分析表如图21所示，黄色单元格中填入机械和运行参数信息，并选择直线电动机型号，即可对直线电动机的适配性进行自动核算。

选型结果				结论： 所选电机：134XJT1K2M10W <b>符合</b> 当前设定条件下的使用要求。
项目	电机参数	分析结果	比值	
最快速度 m/min	150	50	33%	
峰值推力 N	3000	1653	55%	
持续推力 N	1200	779	65%	
项目	参数		备注及说明	
使用条件	轴移动部件重量：	140 kg	轴移动部件质量，不含电机	
	行程	0.45 m		
	最大运动速度	50 m/min		
	最大加速度	9.81 m/s*s		
	倾斜角	30 度		水平轴时填0度
	摩擦系数	0.02		线轨0.02/硬轨0.1
	阻力	20 N		估算线缆、拖链、防护罩等阻力
	安全系数	1.2		
倾斜或垂直轴选项	是否带平衡装置	是	下拉选择	
	平衡系数（平衡比）	1	无平衡装置为0，完全平衡时为1。	
电机选择	电机型号	134XJT1K2M10W	下拉选择	
	电机安装方式	初级运动-次级固定	下拉选择	
	初级规格	134XJT1K2M10-00		
	次级规格	140XJTS4-01		
	次级数量	5 块		
电机参数	额定功率	1.2 kw		
	持续推力	1200 N		
	峰值推力	3000 N		
	磁吸力	6800 N		
	最高速度	150 m/min		
	运动部分重量	12 kg		

图 21

### 6.2 直线电动机配套驱动的选型

直线电动机配套 GR 系列驱动单元，380V 的直线电动机配置 GR3000 的驱动单元，选型原则以直线电动机峰值电流作为参考：

$$\frac{\text{驱动模块电流} * 0.85}{1.414} > \text{直线电动机峰值电流}$$

如：134XJT1K2M10W 直线电动机，峰值电流 21A，则选 GR3050 驱动单元，  
(50\*0.85) / 1.414=30 > 21，满足要求。

## 7 发热功率计算及水冷机选用

### 7.1 直线电动机冷却水路安装

当多轴使用水冷直线电动机时，冷却管路必须以并联方式安装。

由于 340XJT 系列直线电动机发热功率较大，故单个直线电动机需两路循环，如图 22 所示。



图 22

### 7.2 直线电动机发热功率计算

由于直线电动机运行时主要以铜耗为主，故计算发热功率时可近似为其铜耗，计算公式如下。

$$P_{Cu} = 3 * I^2 * R = 3 * \left( \frac{F}{F_N} * I_N \right)^2 * R$$

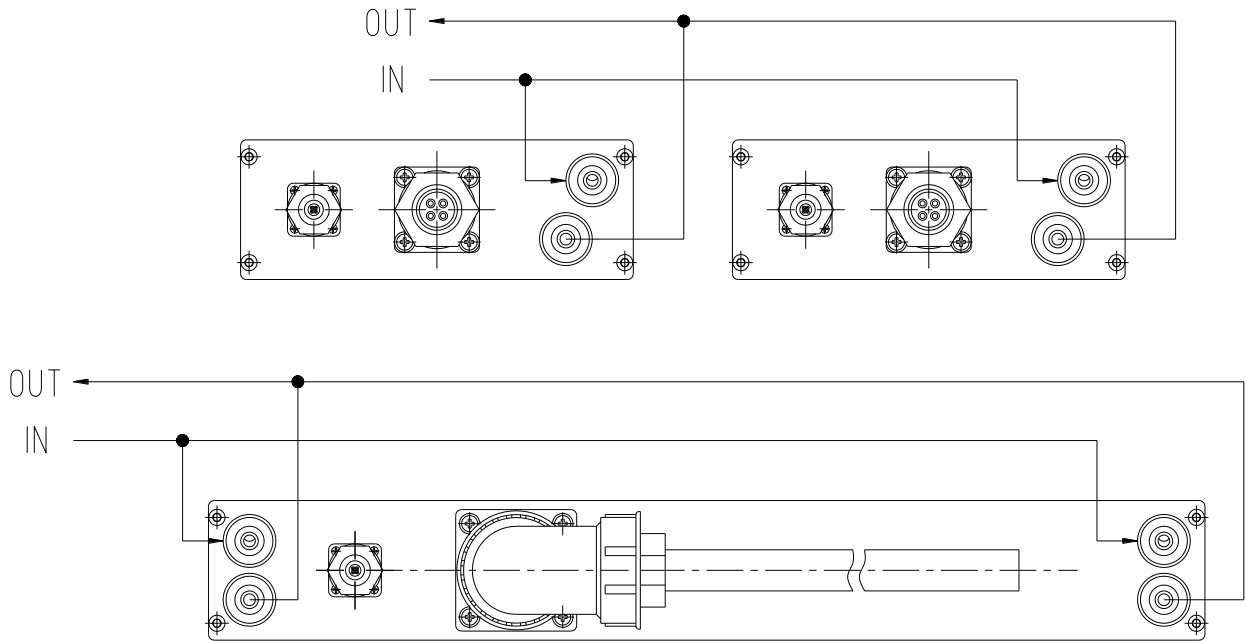
如按 6.1 直线电动机选型计算所得的计算持续推力  $F=779N$ ，直线电动机型号 134XJT1K2M10W 的  $F_N=1200N$ ， $I_N=8A$ ， $120^{\circ}C$  时的  $R=4.73\Omega$ ，则选用该款直线电动机在计算工况下的铜耗如下。

$$P_{Cu} = 3 * I^2 * R = 3 * \left( \frac{F}{F_N} * I_N \right)^2 * R = 3 * \left( \frac{779}{1200} * 8 \right)^2 * 4.73 = 3827(W)$$

### 7.3 冷水机的选用

冷水机的选用主要依据以下两点：

- 1) 制冷功率要大于直线电动机总发热功率：

$$P_{\text{制冷}} > \sum P_{\text{Cu}}$$

2) 最小流量要大于直线电动机最小流量总和:

$$Q_{\text{冷水机}} > \sum Q_{\text{电机}}$$

## 8 直线电动机线缆

### 8.1 温度保护配置

直线电动机共埋有两组温度传感器，一组为 KTY84/130 硅热敏电阻，主要用于监测温度变化；另一组为 PTC130 过热保护温度传感器，用于绕组内部温度过热断电保护。

#### 8.1.1 KTY84/130 硅热敏电阻

KTY84/130 硅热敏电阻电气参数见表 10，阻温特性曲线及配置图如图 23 所示。

表 10

序号	电气参数	符号	测试条件	最小值	标准值	最大值	单位
1	25°C电阻值	R <sub>25</sub>	恒温 25°C±0.05°C	577	603	629	Ω
2	100°C电阻值	R <sub>100</sub>	恒温 100°C±0.05°C	970	1000	1030	Ω
3	绝缘电阻	/	DC=100V	100	/	/	MΩ
4	最大工作电流	I <sub>max</sub>	/	/	/	8	mA
5	额定工作电流	I <sub>n</sub>	/	/	5	/	mA
6	工作温度	T <sub>a</sub>	-40°C~210°C				



图 23



8.1.2 PTC130 过热保护温度传感器

PTC130 过热保护温度传感器电气参数见表 11，阻温特性曲线及配置图如图 24 所示。

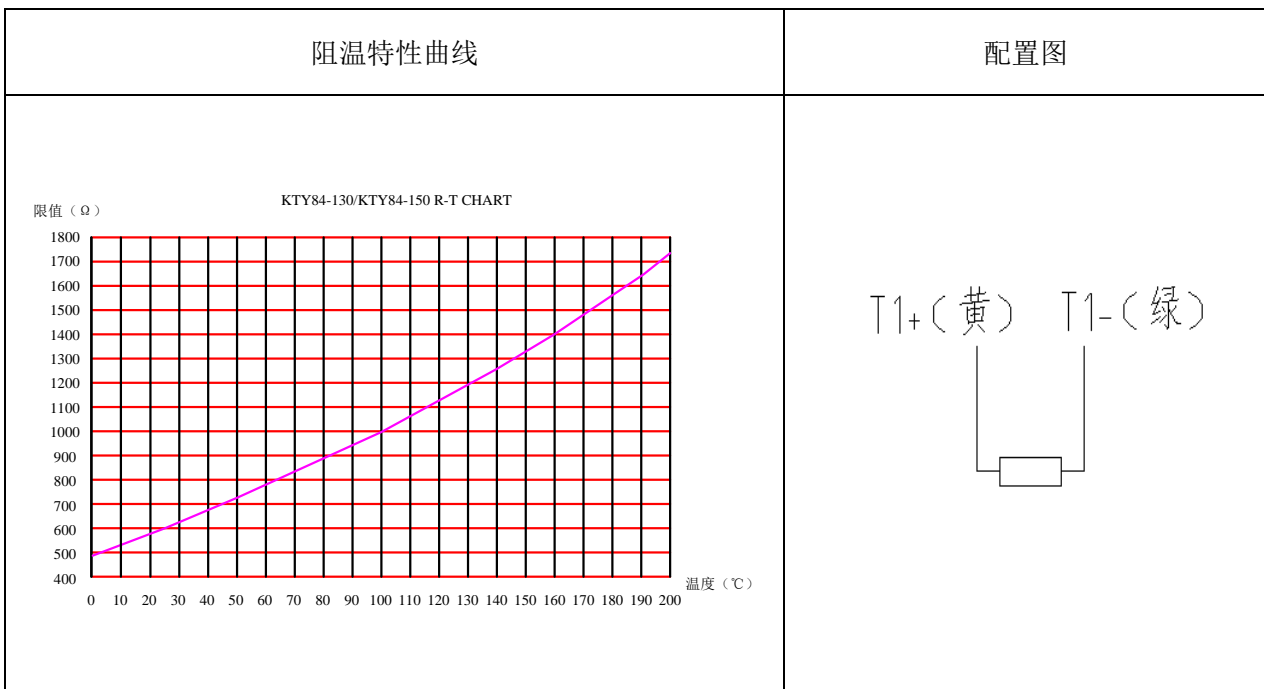
表 11

序号	项目	技术要求
1	最大直流工作电压	30Vdc
2	正常使用直流电压/电流	电压 $\leq 2.5\text{V}$ /电流 $< 2\text{mA}$
3	控温精度	$\pm 5^\circ\text{C}$
4	室温下阻值 $R_{25}$ ( $T=25^\circ\text{C}\pm 1^\circ\text{C}$ )	$\leq 100\Omega$
5	TK+5 $^\circ\text{C}$	$\geq 1330\Omega$
6	TK-5 $^\circ\text{C}$	$\leq 550\Omega$
7	TK+15 $^\circ\text{C}$	$\geq 4000\Omega$
8	-20 $^\circ\text{C}\sim\text{TK}-20^\circ\text{C}$	$\leq 250\Omega$
9	测试电压 (DC)	$\leq 2.5\text{Vdc}$
10	反应时间	$< 5\text{s}$
11	绝缘强度 (AC)	2.5kV/60s
12	0.12mm <sup>2</sup> 引线	$\leq 0.15\Omega/\text{m}$



图 24

### 8.2 温控信号线 (XJT-00-701)



接线表:

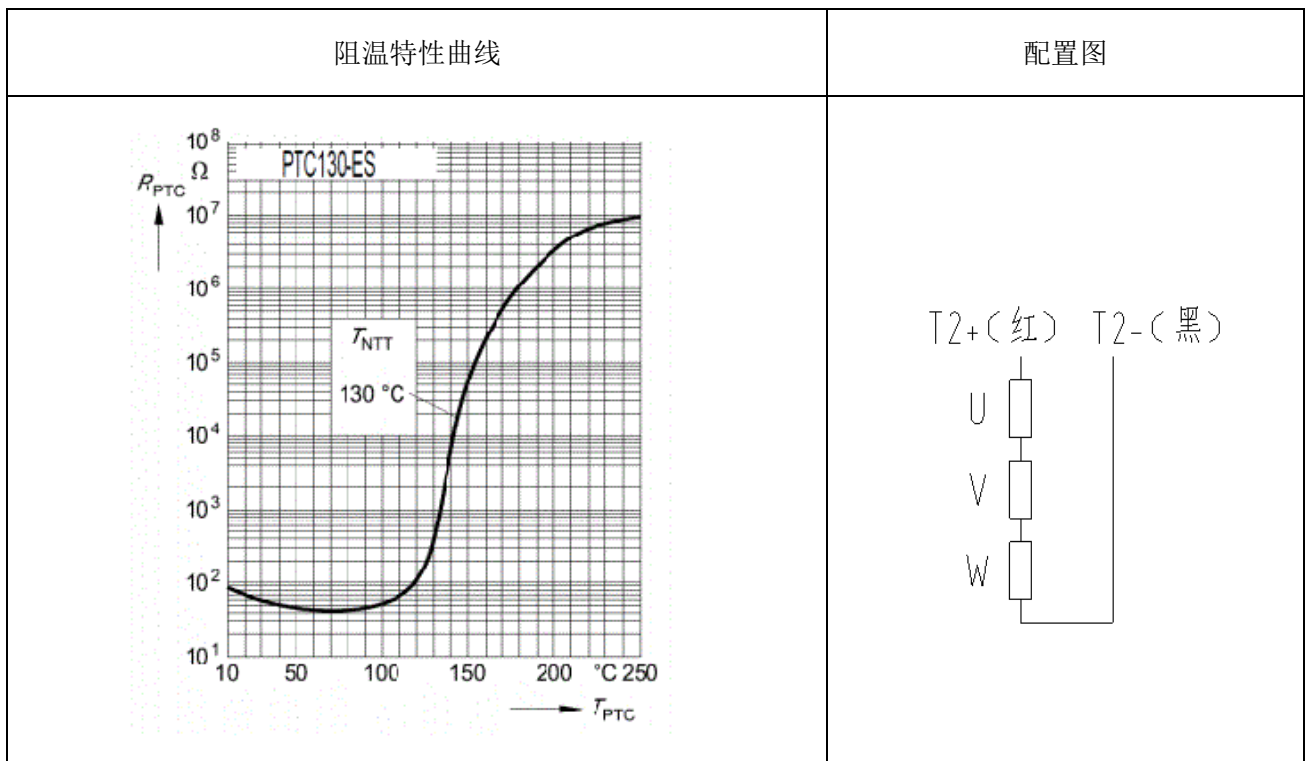
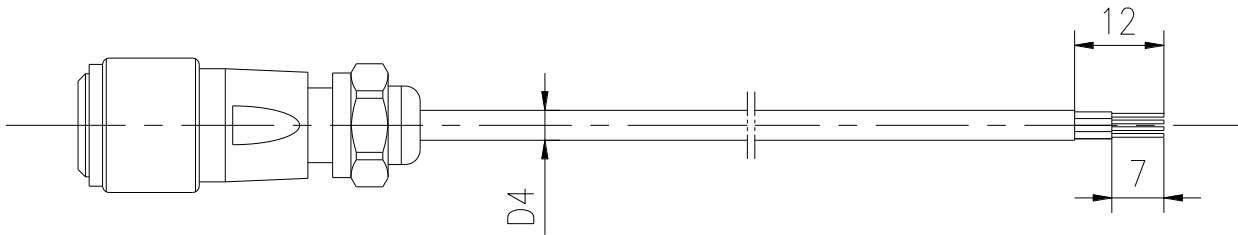
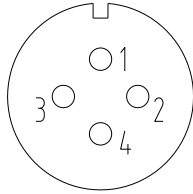

传感器型号	KTY84/130		PTC130	
护套线颜色	黄	绿	红	黑
插头接线脚编号	1	2	3	4

图 25

### 8.3 电源线

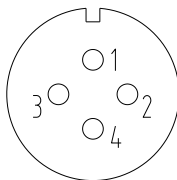
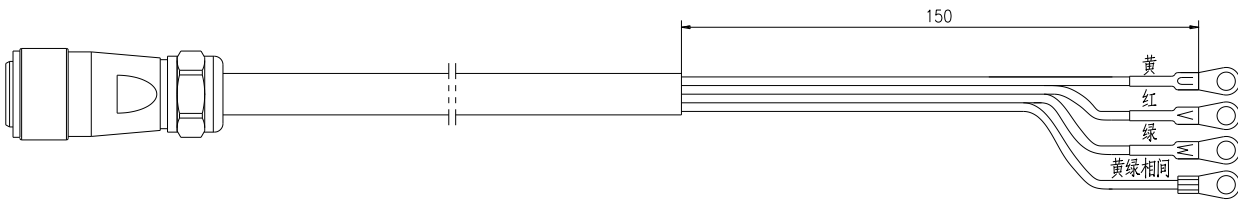

接线表:

电源线颜色	黄绿(地)	黄(U)	红(V)	绿(W)
插头接线脚编号	1	2	3	4

图 26

表 12

电源线	适配连续电流 (A)	线径约 (mm)	最小弯曲半径 (mm)
XJT-00-702	<15	Φ12	50
XJT-00-703	<25	Φ13	50
XJT-00-704	<35	Φ21	80

## 9 直线电动机的贮存

电动机应存放在环境温度为 $-40^{\circ}\text{C} \sim 55^{\circ}\text{C}$ 、相对湿度不大于 95%（无凝露）的清洁通风良好的库房内，空气中不得含有腐蚀性气体。

## 10 直线电动机的运输

运输过程中应小心轻放，避免碰撞和冲击，严禁与酸、碱等腐蚀性物质放在一起；不应置于露天环境中进行运输，注意防水、防雨雪、防尘和机械损伤。

## 11 质量保证期

用户在符合产品运输、储存、安装、调试、维修及遵守使用规程的条件下，自本公司发货之日起（依发货凭证为据）12 个月内，凡直线电动机因制造质量不良而发生损坏或不能正常使用时，本公司负责免费修理。

## 12 订货说明

本使用说明书所列直线电动机为本公司推荐型号规格，可适应多数应用场合，如果您有其他需求，我们可按您的需求提供其他规格的直线电动机。



 In this Operating Manual, we will describe various matters related to XJT Series AC Permanent Magnet Synchronous Linear Motor to the greatest extent. It is not possible to describe in detail all the operations that need not be done and/or cannot be done due to length constraints and specific product usage. Therefore, anything not specifically indicated in this Operating Manual shall be deemed to be the operation that is "impossible" or "not permitted".

 The copyright of this Operating Manual belongs to GSK CNC Equipment Co., Ltd., and it is illegal for any units or individuals to publish or copy it. GSK CNC Equipment Co., Ltd. reserves the right to investigate their legal liabilities.

## Foreword

**Dear customer:**

**The Company is honored and grateful to you for choosing XJT Series AC Permanent Magnet Synchronous Linear Motor (hereafter referred to as the Linear Motor) from GSK CNC Equipment Co., Ltd.**

**Please read this Operating Manual carefully before installing and using the product in order to ensure the motor safety and the normal and effective operation.**

## Safety Warnings and Precautions



**Improper installation and operation may cause accidents!**  
Prior to installation and use, the operation instructions must be read carefully.

Warning sign for primary assembly:



High Temperature



High Voltage

Warning sign for secondary assembly:

Approach Warning:



强磁危险



Other precautions:

- 1 Prior to installation and use, please confirm whether the linear motor (including primary and secondary assemblies and cooling accessories) is damaged or destroyed. If there is any damage, please contact our company or the dealer in time.
- 2 Under normal climatic conditions, use a 500V megameter to measure the insulation resistance values of three phases U , V and W of primary assembly winding to the ground and the equipment housing, which should not be less than 20 M $\Omega$ .
- 3 Assembly and operation must be implemented by professionals.
- 4 During disassembly and assembly of secondary assemblies, approaching of metal objects should be avoided, and special attention shall be paid to the risk of hand clamping injury, so this must be handled discreetly.
- 5 When wiring, please connect the power cords marked with "UVW" with the corresponding UVW wires of the drive unit, and ensure that the earthing is firm and reliable.
- 6 The Company will not assume any responsibility for any unauthorized modification of the product by the user, and the warranty of the product will be invalidated accordingly.

All models, specifications and designs are subject to change without notice!

## **Safety Responsibility**

### **Manufacturer's responsibility for safety**

- The manufacturer shall be responsible for the hazard of the supplied linear motor and accompanying accessories that have been eliminated and/or controlled in design and structure.
- The manufacturer shall be responsible for the safety of the supplied linear motor and accompanying accessories.
- The manufacturer shall be responsible for the use information and advice provided for the user.

### **User's responsibilities for safety**

- Users shall be familiar with and master the safe operation through learning and training of linear motor safety operation.
- Users shall be responsible for the safety and hazards as a result of adding, changing or modifying the original linear motor and accessories by themselves.
- Users shall be responsible for any hazard caused by failure to operate, adjust, maintain, install, store and transport the Product in accordance with the Operation Instructions.

**This Operation Instructions should be kept by end users.**

**Thank you very much——Thank you very much for using the products  
of GSK CNC Equipment Co., Ltd.  
and your friendly support for us!**



## 目 录

<b>1</b>	<b>Product Features</b> .....	<b>1</b>
<b>2</b>	<b>Model Description</b> .....	<b>2</b>
<b>3</b>	<b>Main Technical Parameters</b> .....	<b>3</b>
3.1	Main Technical Parameters of 88XJT Series Linear Motor.....	3
3.2	Main Technical Parameters of 100XJT Series Linear Motor .....	4
3.3	Main Technical Parameters of 134XJT Series Linear Motor .....	5
3.4	Main Technical Parameters of 182XJT Series Linear Motor .....	7
3.5	Main Technical Parameters of 242XJT Series Linear Motor .....	9
3.6	Main Technical Parameters of 334XJT Series Linear Motor .....	11
3.7	Main Technical Parameters of 340XJT Series Linear Motor .....	13
<b>4</b>	<b>Outline and Installation Dimensions</b> .....	<b>14</b>
4.1	Outline and Installation Dimensions of 88XJT Series Linear Motor.....	14
4.2	Outline and Installation Dimensions of 100XJT Series Linear Motor .....	14
4.3	Outline and Installation Dimensions of 134XJT Series Linear Motor .....	15
4.4	Outline and Installation Dimensions of 182XJT Series Linear Motor .....	16
4.5	Outline and Installation Dimensions of 242XJT Series Linear Motor.....	17
4.6	Outline and Installation Dimensions of 334XJT Series Linear Motor .....	18
4.7	Outline and Installation Dimensions of 340XJT Series Linear Motor .....	19
<b>5</b>	<b>Installation Requirements and Precautions</b> .....	<b>20</b>
5.1	Structure of linear motor .....	20
5.2	Installation layout .....	21
5.3	Installation requirements .....	22
5.4	Order of installation.....	22
5.5	Influence of air gap on continuous thrust.....	23
5.5	Parallel connection .....	24
5.6	Other installation precautions .....	24
<b>6</b>	<b>Type Selection of Linear Motor</b> .....	<b>25</b>
6.1	Calculation method for type selection of linear motor.....	25
6.2	Type selection of linear motor matching drive.....	27
<b>7</b>	<b>Calculation of Heating Power and Selection of Water Cooler</b> .....	<b>27</b>
7.1	Installation of cooling water pipelines for the linear motor.....	27
7.2	Calculation of heating power of linear motor .....	28
7.3	Selection of water cooler.....	28
<b>8</b>	<b>Cables of Linear Motor</b> .....	<b>28</b>
8.1	Temperature protection.....	28

8.1.1	KTY84/130 silicon thermistor	29
8.1.2	PTC130 overheat protection temperature sensor	30
8.2	Temperature control signal line (XJT-00-701)	31
8.3	Power cord	31
<b>9</b>	<b>Storage of Linear Motor</b>	<b>32</b>
<b>10</b>	<b>Transportation of Linear Motor</b>	<b>32</b>
<b>11</b>	<b>Warranty Period</b>	<b>32</b>
<b>12</b>	<b>Order Description</b>	<b>32</b>

## 1 Product Features

The XJT series permanent magnet AC synchronous linear motors independently developed and manufactured by GSK CNC Equipment Co., Ltd. are made of high-performance rare earth permanent magnet materials, characterized by high power density, high dynamic response, low thrust fluctuation and high reliability, which can meet the extensive demands such as CNC machine and automation equipment.

Due to its principle and structural characteristics, linear motor has built-in advantages over "screw + rotating motor structure", mainly shown in the following aspects:

- **Simple structure:** its mechanical structure is relatively simple, with few mechanical transmission parts and components.
- **High speed:** the primary components are installed on the guide rail that can run at a high speed, and they are not restricted by the use limit of traditional lead screw, bearing and other mechanical accessories. It is easy to get a high and stable speed and acceleration (up to 4g when measured)
- **High dynamic response:** the direct delivery of driving force achieves both high dynamic performance and good accuracy without overshoot.
- **High precision:** it has excellent dynamic response performance and is equipped with high-precision linear encoder, so that high precision can be obtained in each speed segment.
- **Precision retention ability:** the easily worn parts such as lead screw rod and bearing are canceled, and the "Zero Wear Rate" in theory makes the precision retention ability more excellent.
- **Unlimited travel:** the travel is not affected by the length of the lead screw and its own stiffness, and can be extended infinitely.

## 2 Model Description

For example:

134   XJT   1K2   M   10   W  
 ①   ②   ③   ④   ⑤   ⑥

S/N	Meaning
①	Frame number.
②	Permanent magnet synchronous linear motor.
③	Rated thrust of linear motor (denoted by three digits, unit: N. If it is less than 1000N, it is directly denoted by three digits, for example, 050 represents 50N, and 645 represents 645N; If it is greater than 1000N, it is denoted by □K□, for example, 1K2 represents 1200N, 8K1 represents 8100N; If it is greater than 10000N, it is denoted by □□K, for example, 13K represents 13000N, 17K represents 17000N).
④	Input voltage of drive unit (L: 220V, M: 380V).
⑤	Rated speed code (denoted by two digits, and its value is two digits ×0.1, unit: m/s. For example, 20×0.1=2 m/s, 13×0.1=1.3 m/s).
⑥	Cooling method (W: water cooling, N: self-cooling).

### 3 Main Technical Parameters

#### 3.1 Main Technical Parameters of 88XJT Series Linear Motor

Table 1

Item	Model	
	88XJT260L20N	88XJT260M20N
Rated power (kW)	0.52	
Polar distance $2\tau$ (mm)	30	
Input voltage of drive unit	Single phase AC 220V	Three-phase AC 380V
Continuous thrust (N)	260	260
Continuous current (A)	4.3	2.3
Peak thrust (N)	1000	1000
Peak current (A)	16.2	8.9
Rated speed (m/s)	2	2
Max. speed (m/s)	4	4
Thrust constant (N/A)	60.5	113
Opposite potential constant (Vs/m)	21.5	39.9
Phase resistance at 25°C (Ω)	1.84	6.85
Phase resistance at 120°C (Ω)	2.52	9.35
Forward direction suction force (N)	1700	1700
Specifications of primary assembly	88XJT260L20-00	88XJT260M20-00
Weight of primary assembly (kg)	3.6	
Insulation grade	F (GB/T 755—2019/IEC 60034-1: 2017)	
Protection grade	IP65 (GB/T 4208—2017/IEC 60529: 2013, GB/T 4942—2021/IEC 60034-5: 2020)	
Specifications of secondary assembly	100XJTS4-00	
Weight of secondary assembly (kg)	0.7 (single piece length of 120mm)	

Thrust-Speed characteristic diagram (F-n) (A: continuous duty zone; B: intermittent duty zone)

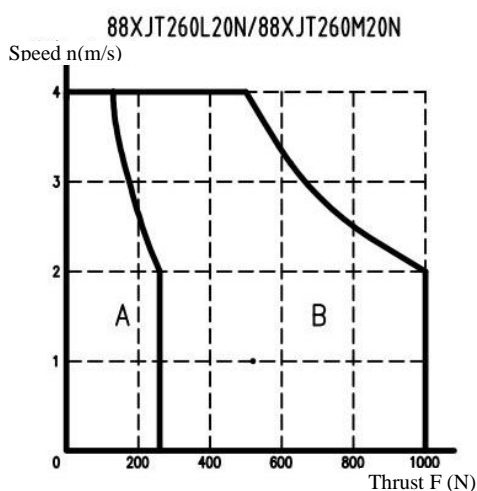

3.2 Main Technical Parameters of 100XJT Series Linear Motor

Table 2

Item	Model	
	100XJT400M20W	100XJT600M20W
Rated power (kW)	0.8	1.2
Polar distance $2\tau$ (mm)	30	
Input voltage of drive unit	Three-phase AC380	
Continuous thrust (N)	400 (200)	600 (300)
Continuous current (A)	4.5	6.5
Peak thrust (N)	1000	1500
Peak current (A)	12	17
Rated speed (m/s)	2	2
Max. speed (m/s)	4	4
Thrust constant (N/A)	88.8	92.3
Opposite potential constant (Vs/m)	30.8	32.2
Phase resistance at 25°C ( $\Omega$ )	4.3	3.49
Phase resistance at 120°C ( $\Omega$ )	5.87	4.76
Forward direction suction force (N)	2600	3900
Min. cooling flow (L/min)	2.5	
Specifications of primary assembly	100XJT400M20-00	100XJT600M20-00
Weight of primary assembly (kg)	4	5.6
Insulation grade	F (GB/T 755-2019/IEC 60034-1: 2017)	
Protection grade	IP65 (GB/T 4208-2017/IEC 60529: 2013, GB/T 4942-2021/IEC 60034-5: 2020)	
Specifications of secondary assembly	100XJTS4-00	
Weight of secondary assembly (kg)	0.7 (single piece length of 120mm)	
Precision cooling cover (optional)	100XJT400-02	100XJT600-02
Weight of precision cooling cover (kg)	0.6	0.8

Notes: the continuous thrust without water inflow is in brackets.

Thrust-Speed characteristic diagram (F-n) (A: continuous duty zone; B: intermittent duty zone)

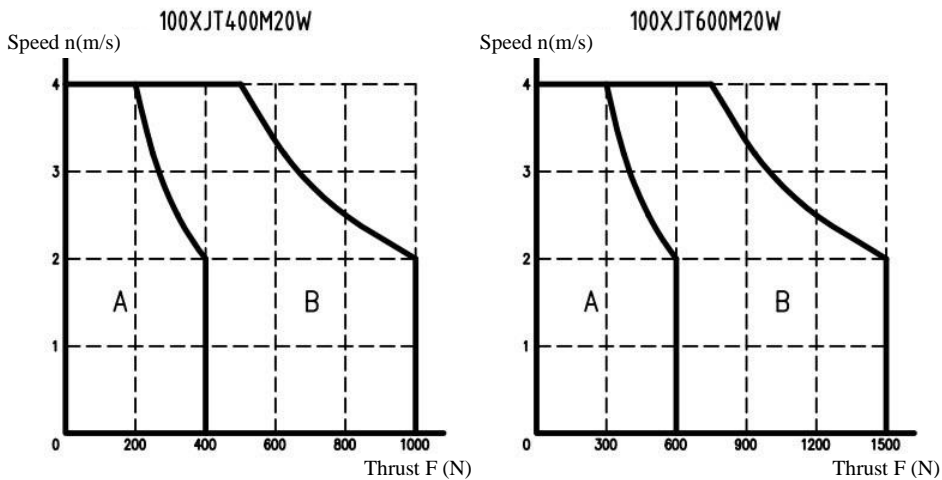

### 3.3 Main Technical Parameters of 134XJT Series Linear Motor

Table 3

Item	Model		
	134XJT1K2L10W	134XJT1K8L10W	134XJT2K4L10W
Rated power (kW)	1.2	1.8	2.4
Polar distance $2\tau$ (mm)	46		
Input voltage of drive unit	Single phase AC 220V		
Continuous thrust (N)	1200 (600)	1800 (900)	2400 (1200)
Continuous current (A)	10	14	18
Peak thrust (N)	3000	4500	6000
Peak current (A)	25	35	45
Rated speed (m/s)	1	1	1
Max. speed (m/s)	1.5	1.5	1.5
Thrust constant (N/A)	120	129	134
Opposite potential constant (Vs/m)	44	45	48
Phase resistance at 25°C ( $\Omega$ )	2.0	1.7	1.02
Phase resistance at 120°C ( $\Omega$ )	2.75	2.37	1.39
Forward direction suction force (N)	6800	10200	13600
Min. cooling flow (L/min)	2.5		
Specifications of primary assembly	134XJT1K2L10-00	134XJT1K8L10-00	134XJT2K4L10-00
Weight of primary assembly (kg)	12	17	22
Insulation grade	F (GB/T 755-2019/IEC 60034-1: 2017)		
Protection grade	IP65 (GB/T 4208-2017/IEC 60529: 2013, GB/T 4942-2021/IEC 60034-5: 2020)		
Specifications of secondary assembly	140XJTS4-01		
Weight of secondary assembly (kg)	2.4 (single piece length of 184mm)		
Precision cooling cover (optional)	134XJT1K2-02	134XJT1K8-02	134XJT2K4-02
Weight of precision cooling cover (kg)	0.9	1.3	1.7

Notes: the continuous thrust without water inflow is in brackets.

Thrust-Speed characteristic diagram (F-n) (A: continuous duty zone; B: intermittent duty zone)

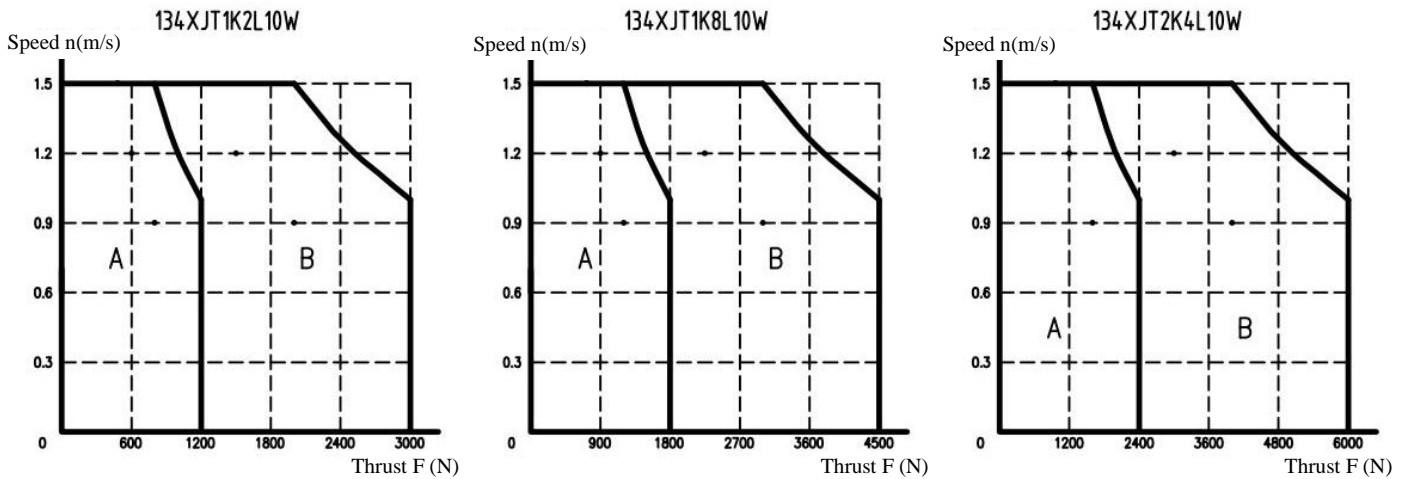
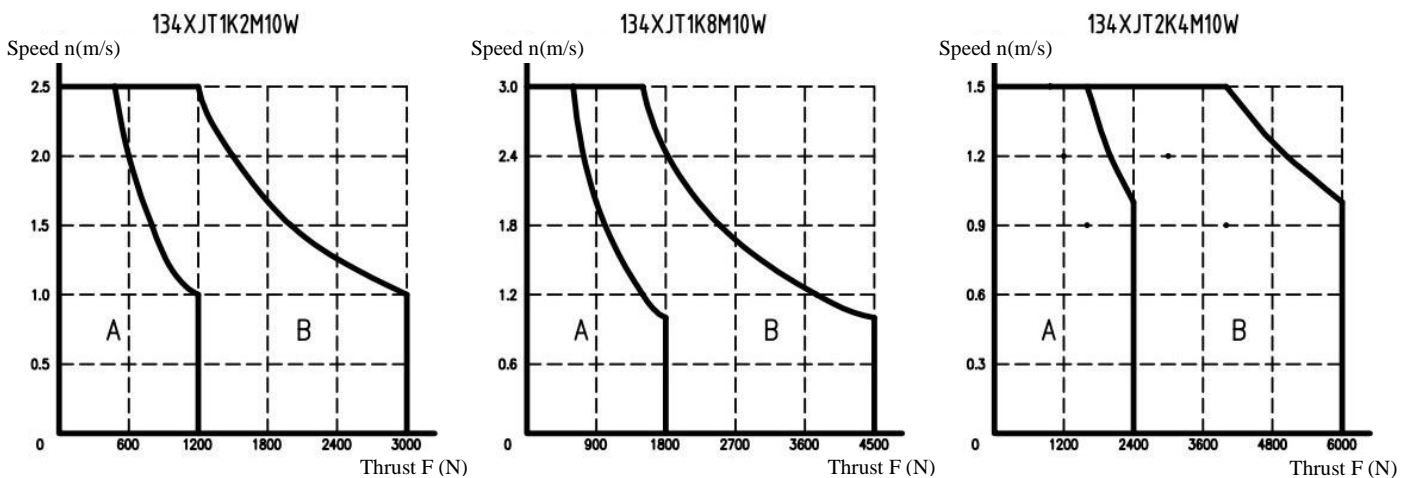

Table 3 (continued)

Item	Model		
	134XJT1K2M10W	134XJT1K8M10W	134XJT2K4M10W
Rated power (kW)	1.2	1.8	2.4
Polar distance 2τ (mm)	46		
Input voltage of drive unit	Three-phase AC 380V		
Continuous thrust (N)	1200 (600)	1800 (900)	2400 (1200)
Continuous current (A)	8	16	12
Peak thrust (N)	3000	4500	6000
Peak current (A)	21	40	30
Rated speed (m/s)	1	1	1
Max. speed (m/s)	2.5	3	1.5
Thrust constant (N/A)	150	112	200
Opposite potential constant (Vs/m)	56	40	69
Phase resistance at 25°C (Ω)	3.46	1.41	2.43
Phase resistance at 120°C (Ω)	4.73	1.93	3.31
Forward direction suction force (N)	6800	10200	13600
Min. cooling flow (L/min)	2.5		
Specifications of primary assembly	134XJT1K2M10-00	134XJT1K8M10-00	134XJT2K4M10-00
Weight of primary assembly (kg)	12	17	22
Insulation grade	F (GB/T 755—2019/IEC 60034-1: 2017)		
Protection grade	IP65 (GB/T 4208—2017/IEC 60529: 2013, GB/T 4942—2021/IEC 60034-5: 2020)		
Specifications of secondary assembly	140XJTS4-01		
Weight of secondary assembly (kg)	2.4 (single piece length of 184mm)		
Precision cooling cover (optional)	134XJT1K2-02	134XJT1K8-02	134XJT2K4-02
Weight of precision cooling cover (kg)	0.9	1.3	1.7

Notes: the continuous thrust without water inflow is in brackets.

Thrust-Speed characteristic diagram (F-n) (A: continuous duty zone; B: intermittent duty zone)





### 3.4 Main Technical Parameters of 182XJT Series Linear Motor

Table 4

Item	Model		
	182XJT1K9L05W	182XJT2K8L05W	182XJT3K8L05W
Rated power (kW)	0.95	1.4	1.9
Polar distance $2\tau$ (mm)	46		
Input voltage of drive unit	Single phase AC 220V		
Continuous thrust (N)	1900 (950)	2800 (1400)	3800 (1900)
Continuous current (A)	15	19	26
Peak thrust (N)	4750	7000	9500
Peak current (A)	38	48	65
Rated speed (m/s)	0.5	0.5	0.5
Max. speed (m/s)	1.5	1.5	1.5
Thrust constant (N/A)	127	147	146
Opposite potential constant (Vs/m)	66	51	51
Phase resistance at 25°C ( $\Omega$ )	1.41	1.1	0.7
Phase resistance at 120°C ( $\Omega$ )	1.92	1.53	0.97
Forward direction suction force (N)	10000	15000	20000
Min. cooling flow (L/min)	2.5		
Specifications of primary assembly	182XJT1K9L05-00	182XJT2K8L05-00	182XJT3K8L05-00
Weight of primary assembly (kg)	16	22	28
Insulation grade	F (GB/T 755–2019/IEC 60034-1: 2017)		
Protection grade	IP65 (GB/T 4208—2017/IEC 60529: 2013, GB/T 4942—2021/IEC 60034-5: 2020)		
Specifications of secondary assembly	188XJTS4-00		
Weight of secondary assembly (kg)	3.8 (single piece length of 184mm)		
Precision cooling cover (optional)	182XJT1K9-02	182XJT2K8-02	182XJT3K8-02
Weight of precision cooling cover (kg)	1.1	1.5	1.7

Notes: the continuous thrust without water inflow is in brackets.

Thrust-Speed characteristic diagram (F-n) (A: continuous duty zone; B: intermittent duty zone)

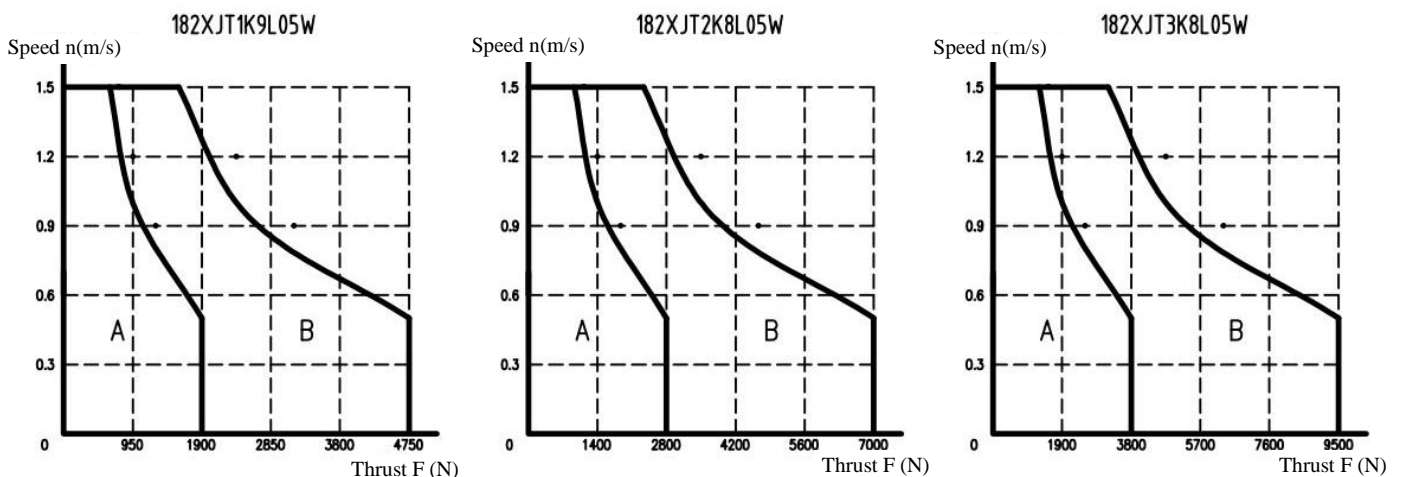
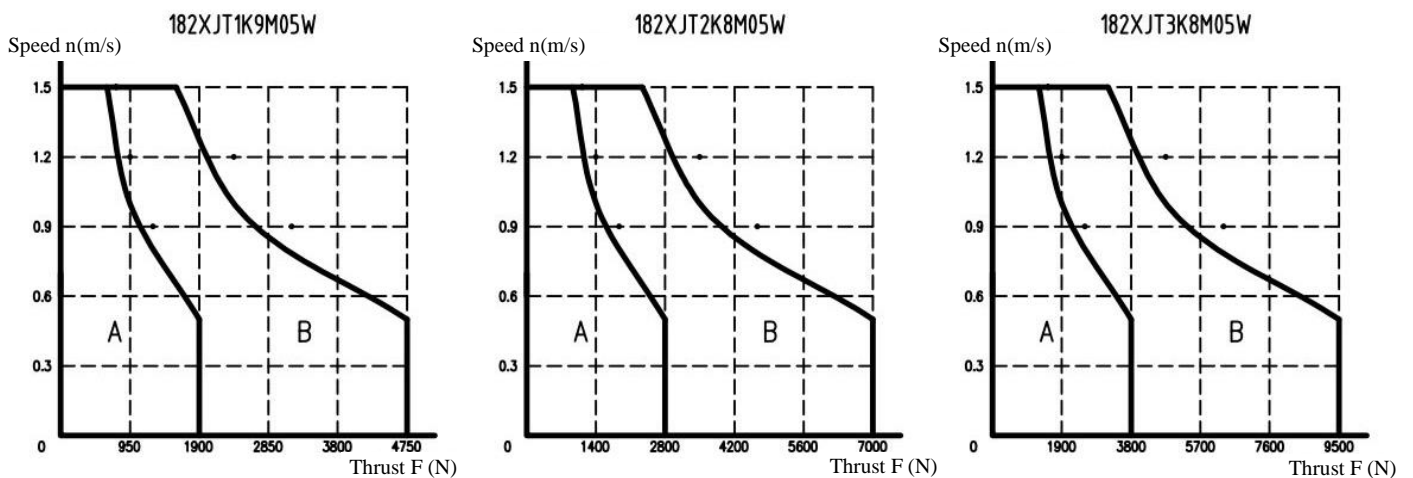

Table 4 (continued)

Item	Model		
	182XJT1K9M05W	182XJT2K8M05W	182XJT3K8M05W
Rated power (kW)	0.95	1.4	1.9
Polar distance 2τ (mm)	46		
Input voltage of drive unit	Three-phase AC 380V		
Continuous thrust (N)	1900 (950)	2800 (1400)	3800 (1900)
Continuous current (A)	9	14	15
Peak thrust (N)	4750	7000	9500
Peak current (A)	23	35	38
Rated speed (m/s)	0.5	0.5	0.5
Max. speed (m/s)	1.5	1.5	1.5
Thrust constant (N/A)	212	200	253
Opposite potential constant (Vs/m)	114	114	89
Phase resistance at 25°C (Ω)	4.37	3.03	2.0
Phase resistance at 120°C (Ω)	5.97	4.13	2.74
Forward direction suction force (N)	10000	15000	20000
Min. cooling flow (L/min)	2.5		
Specifications of primary assembly	182XJT1K9M05-00	182XJT2K8M05-00	182XJT3K8M05-00
Weight of primary assembly (kg)	16	22	28
Insulation grade	F (GB/T 755—2019/IEC 60034-1: 2017)		
Protection grade	IP65 (GB/T 4208—2017/IEC 60529: 2013, GB/T 4942—2021/IEC 60034-5: 2020)		
Specifications of secondary assembly	188XJTS4-00		
Weight of secondary assembly (kg)	3.8 (single piece length of 184mm)		
Precision cooling cover (optional)	182XJT1K9-02	182XJT2K8-02	182XJT3K8-02
Weight of precision cooling cover (kg)	1.1	1.5	1.7

Notes: the continuous thrust without water inflow is in brackets.

Thrust-Speed characteristic diagram (F-n) (A: continuous duty zone; B: intermittent duty zone)



### 3.5 Main Technical Parameters of 242XJT Series Linear Motor

Table 5

Item	Model		
	242XJT2K6L05W	242XJT2K6M05W	242XJT2K6M10W
Rated power (kW)	1.3	1.3	2.6
Polar distance $2\tau$ (mm)	46		
Input voltage of drive unit	Single phase AC 220V	Three-phase AC 380V	
Continuous thrust (N)	2600 (1300)		
Continuous current (A)	20	12	15
Peak thrust (N)	6500	6500	6500
Peak current (A)	50	30	38
Rated speed (m/s)	0.5	0.5	1
Max. speed (m/s)	1.5	1.5	2
Thrust constant (N/A)	130	217	173
Opposite potential constant (Vs/m)	46	77	61
Phase resistance at 25°C ( $\Omega$ )	1.24	3.79	2.32
Phase resistance at 120°C ( $\Omega$ )	1.69	5.17	3.16
Forward direction suction force (N)	13700		
Min. cooling flow (L/min)	2.5		
Specifications of primary assembly	242XJT2K6L05-00	242XJT2K6M05-00	242XJT2K6M10-00
Weight of primary assembly (kg)	21	21	21
Insulation grade	F (GB/T 755—2019/IEC 60034-1: 2017)		
Protection grade	IP65 (GB/T 4208—2017/IEC 60529: 2013, GB/T 4942—2021/IEC 60034-5: 2020)		
Specifications of secondary assembly	248XJTS4-00		
Weight of secondary assembly (kg)	4.6 (single piece length of 184mm)		
Precision cooling cover (optional)	242XJT2K6-02		
Weight of precision cooling cover (kg)	1.2		

Notes: the continuous thrust without water inflow is in brackets.

Thrust-Speed characteristic diagram (F-n) (A: continuous duty zone; B: intermittent duty zone)

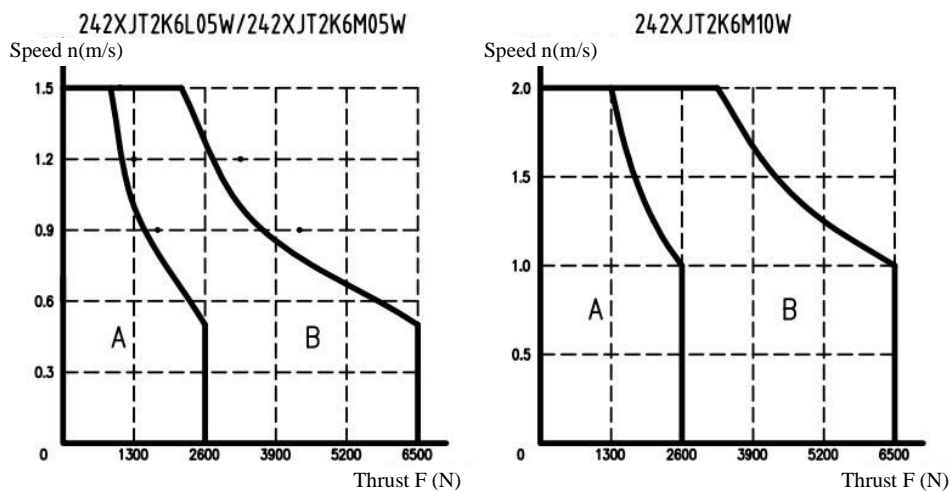
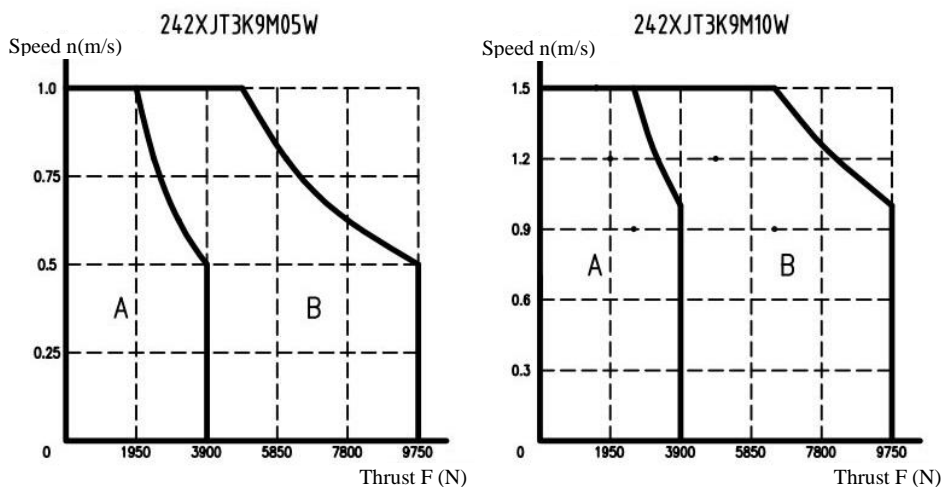

Table 5 (continued)

Item	Model	
	242XJT3K9M05W	242XJT3K9M10W
Rated power (kW)	1.95	3.9
Polar distance 2τ (mm)	46	
Input voltage of drive unit	Three-phase AC 380V	
Continuous thrust (N)	3900 (1950)	3900 (1950)
Continuous current (A)	14	18
Peak thrust (N)	9750	9750
Peak current (A)	35	45
Rated speed (m/s)	0.5	1
Max. speed (m/s)	1	1.5
Thrust constant (N/A)	279	217
Opposite potential constant (Vs/m)	97	75
Phase resistance at 25°C (Ω)	3.81	2.24
Phase resistance at 120°C (Ω)	5.2	3.06
Forward direction suction force (N)	20550	
Min. cooling flow (L/min)	2.5	
Specifications of primary assembly	242XJT3K9M05-00	242XJT3K9M10-00
Weight of primary assembly (kg)	29	29
Insulation grade	F (GB/T 755—2019/IEC 60034-1: 2017)	
Protection grade	IP65 (GB/T 4208—2017/IEC 60529: 2013, GB/T 4942—2021/IEC 60034-5: 2020)	
Specifications of secondary assembly	248XJTS4-00	
Weight of secondary assembly (kg)	4.6 (single piece length of 184mm)	
Precision cooling cover (optional)	242XJT3K9-02	
Weight of precision cooling cover (kg)	1.7	

Notes: the continuous thrust without water inflow is in brackets.

Thrust-Speed characteristic diagram (F-n) (A: continuous duty zone; B: intermittent duty zone)



### 3.6 Main Technical Parameters of 334XJT Series Linear Motor

Table 6

Item	Model	
	334XJT04KM05W	334XJT04KM10W
Rated power (kW)	2	4
Polar distance $2\tau$ (mm)	46	
Input voltage of drive unit	Three-phase AC 380V	
Continuous thrust (N)	4000 (2000)	4000 (2000)
Continuous current (A)	15	20
Peak thrust (N)	10000	10000
Peak current (A)	38	50
Rated speed (m/s)	0.5	1
Max. speed (m/s)	1	1.5
Thrust constant (N/A)	267	200
Opposite potential constant (Vs/m)	93	68
Phase resistance at 25°C ( $\Omega$ )	3.88	2.02
Phase resistance at 120°C ( $\Omega$ )	5.3	2.75
Forward direction suction force (N)	20000	
Min. cooling flow (L/min)	2.5	
Specifications of primary assembly	334XJT04KM05-00	334XJT04KM10-00
Weight of primary assembly (kg)	26	26
Insulation grade	F (GB/T 755–2019/IEC 60034-1: 2017)	
Protection grade	IP65 (GB/T 4208–2017/IEC 60529: 2013, GB/T 4942–2021/IEC 60034-5: 2020)	
Specifications of secondary assembly	340XJTS4-00	
Weight of secondary assembly (kg)	7.5 (single piece length of 184mm)	
Precision cooling cover (optional)	334XJT04K-02	
Weight of precision cooling cover (kg)	1.4	

Notes: the continuous thrust without water inflow is in brackets.

Thrust-Speed characteristic diagram (F-n) (A: continuous duty zone; B: intermittent duty zone)

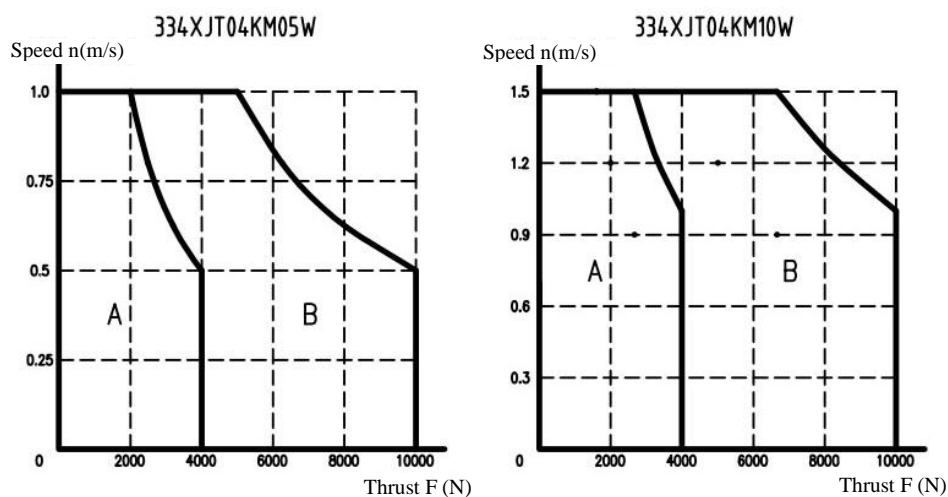
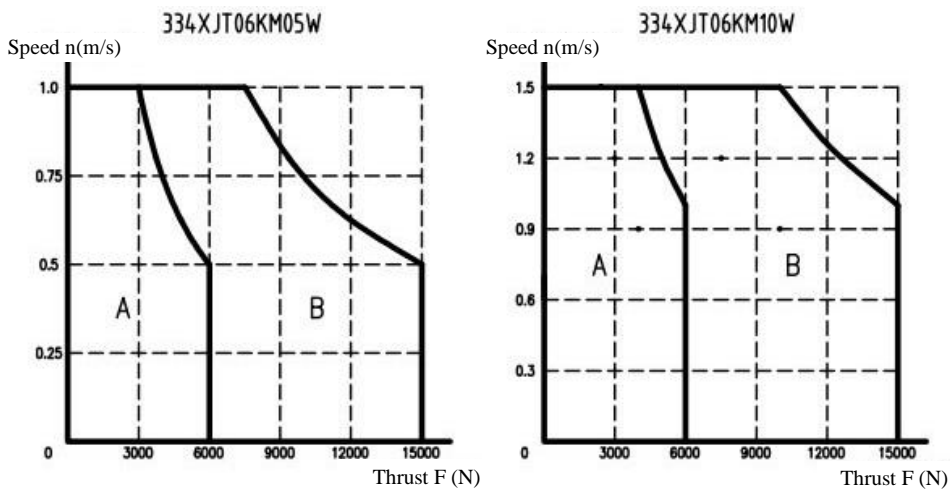

Table 6 (continued)

Item	Model	
	334XJT06KM05W	334XJT06KM10W
Rated power (kW)	3	6
Polar distance 2τ (mm)	46	
Input voltage of drive unit	Three-phase AC 380V	
Continuous thrust (N)	6000 (3000)	6000 (3000)
Continuous current (A)	23	30
Peak thrust (N)	15000	15000
Peak current (A)	58	75
Rated speed (m/s)	0.5	1
Max. speed (m/s)	1	1.5
Thrust constant (N/A)	261	200
Opposite potential constant (Vs/m)	92	69
Phase resistance at 25°C (Ω)	2.56	1.36
Phase resistance at 120°C (Ω)	3.5	1.86
Forward direction suction force (N)	30000	
Min. cooling flow (L/min)	2.5	
Specifications of primary assembly	334XJT06KM05-00	334XJT06KM10-00
Weight of primary assembly (kg)	39	39
Insulation grade	F (GB/T 755—2019/IEC 60034-1: 2017)	
Protection grade	IP65 (GB/T 4208—2017/IEC 60529: 2013, GB/T 4942—2021/IEC 60034-5: 2020)	
Specifications of secondary assembly	340XJTS4-00	
Weight of secondary assembly (kg)	7.5 (single piece length of 184mm)	
Precision cooling cover (optional)	334XJT06K-02	
Weight of precision cooling cover (kg)	1.9	

Notes: the continuous thrust without water inflow is in brackets.

Thrust-Speed characteristic diagram (F-n) (A: continuous duty zone; B: intermittent duty zone)



### 3.7 Main Technical Parameters of 340XJT Series Linear Motor

Table 7

Item	Model	
	340XJT08KM05W	340XJT08KM10W
Rated power (kW)	4	8
Polar distance $2\tau$ (mm)	46	
Input voltage of drive unit	Three-phase AC 380V	
Continuous thrust (N)	8000 (4000)	8000 (4000)
Continuous current (A)	30	40
Peak thrust (N)	20000	20000
Peak current (A)	75	100
Rated speed (m/s)	0.5	1
Max. speed (m/s)	1	1.5
Thrust constant (N/A)	267	200
Opposite potential constant (Vs/m)	90	69
Phase resistance at 25°C ( $\Omega$ )	1.74	1.02
Phase resistance at 120°C ( $\Omega$ )	2.38	1.39
Forward direction suction force (N)	40000	
Min. cooling flow (L/min)	2.5	
Specifications of primary assembly	340XJT08KM05-00	334XJT08KM10-00
Weight of primary assembly (kg)	51	51
Insulation grade	F (GB/T 755—2019/IEC 60034-1: 2017)	
Protection grade	IP65 (GB/T 4208—2017/IEC 60529: 2013, GB/T 4942—2021/IEC 60034-5: 2020)	
Specifications of secondary assembly	340XJTS4-00	
Weight of secondary assembly (kg)	7.5 (single piece length of 184mm)	
Precision cooling cover (optional)	340XJT08K-02	
Weight of precision cooling cover (kg)	2.4	

Notes: the continuous thrust without water inflow is in brackets.

Thrust-Speed characteristic diagram (F-n) (A: continuous duty zone; B: intermittent duty zone)

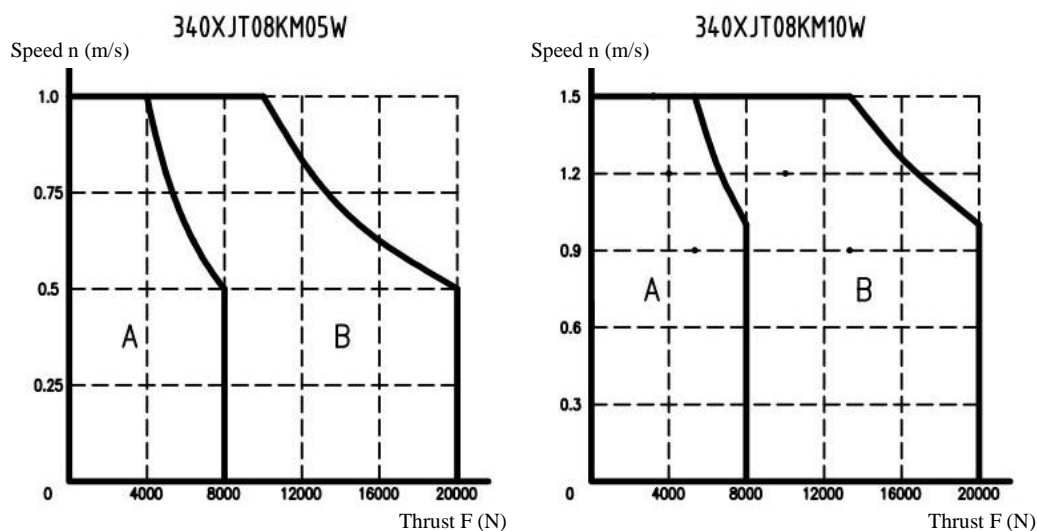

## 4 Outline and Installation Dimensions

### 4.1 Outline and Installation Dimensions of 88XJT Series Linear Motor

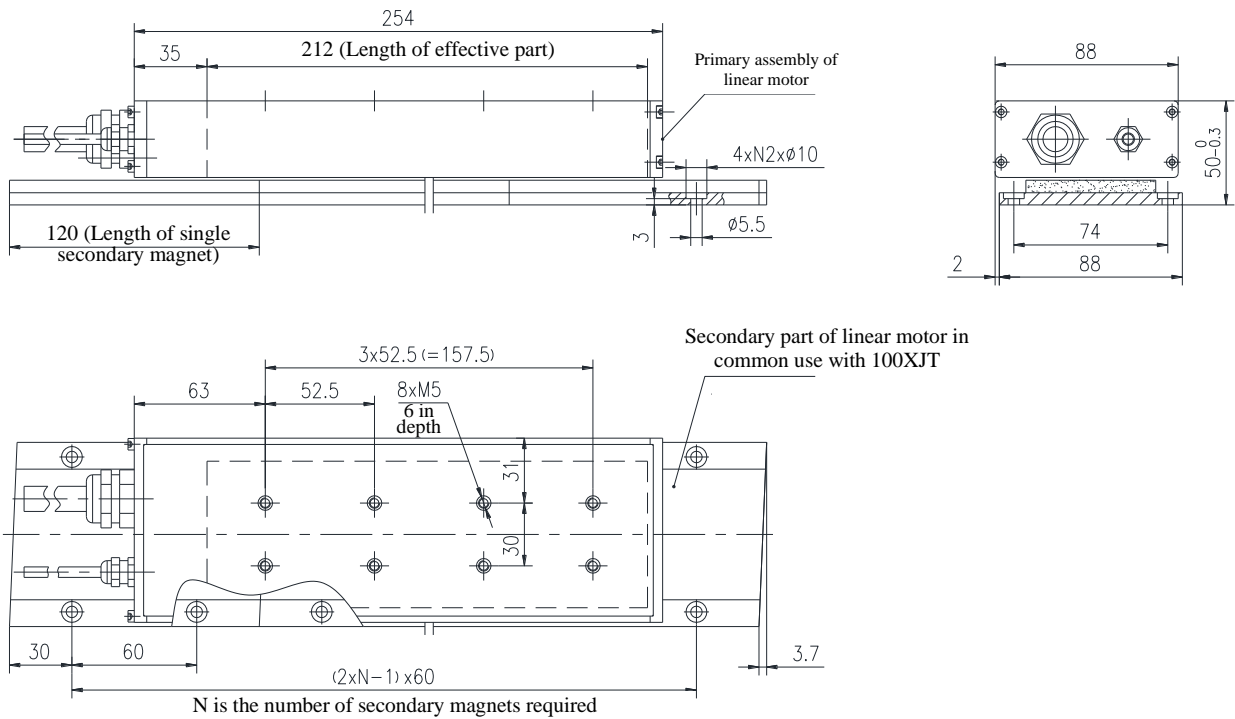

Figure 1

### 4.2 Outline and Installation Dimensions of 100XJT Series Linear Motor

With precision cooling cover

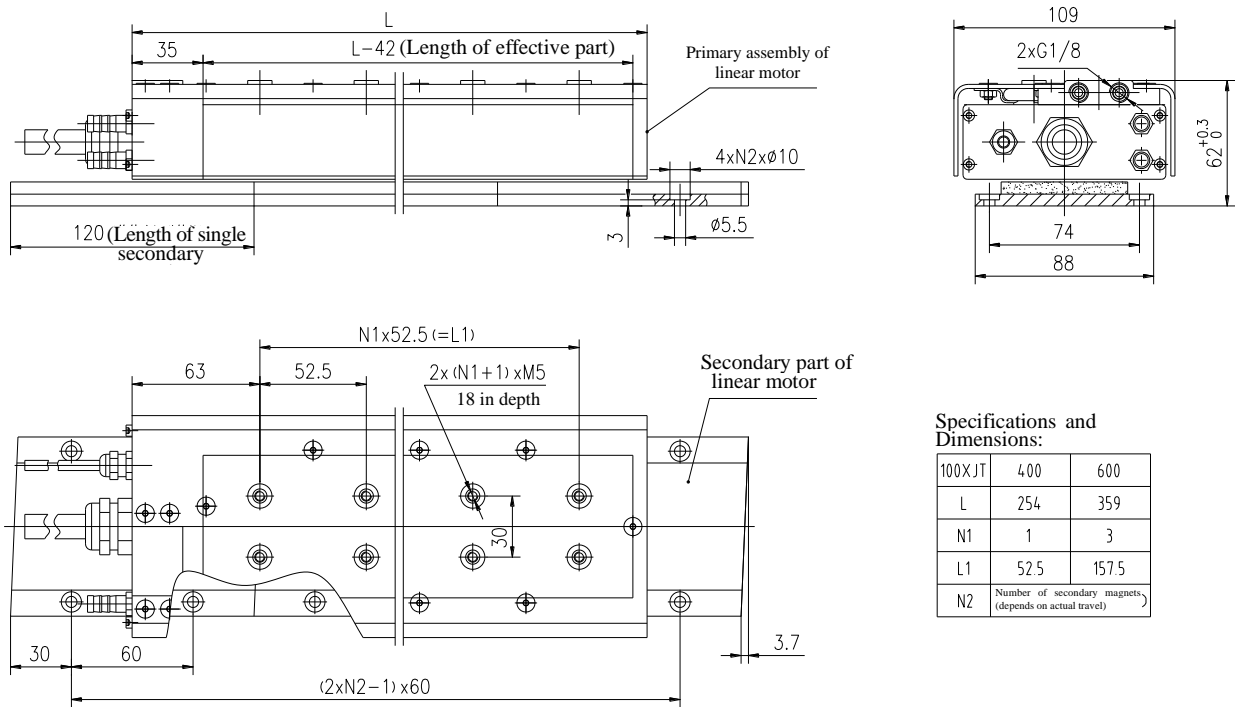

Figure 2



Without precision cooling cover

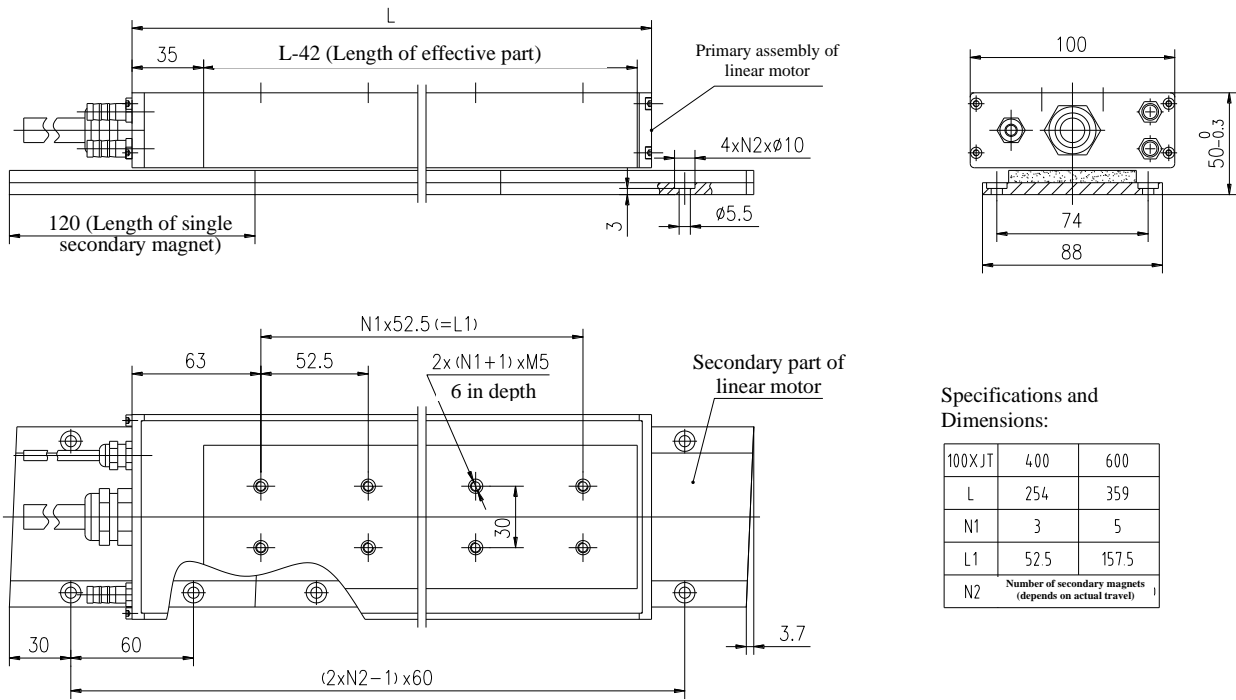

Figure 3

4.3 Outline and Installation Dimensions of 134XJT Series Linear Motor

With precision cooling cover

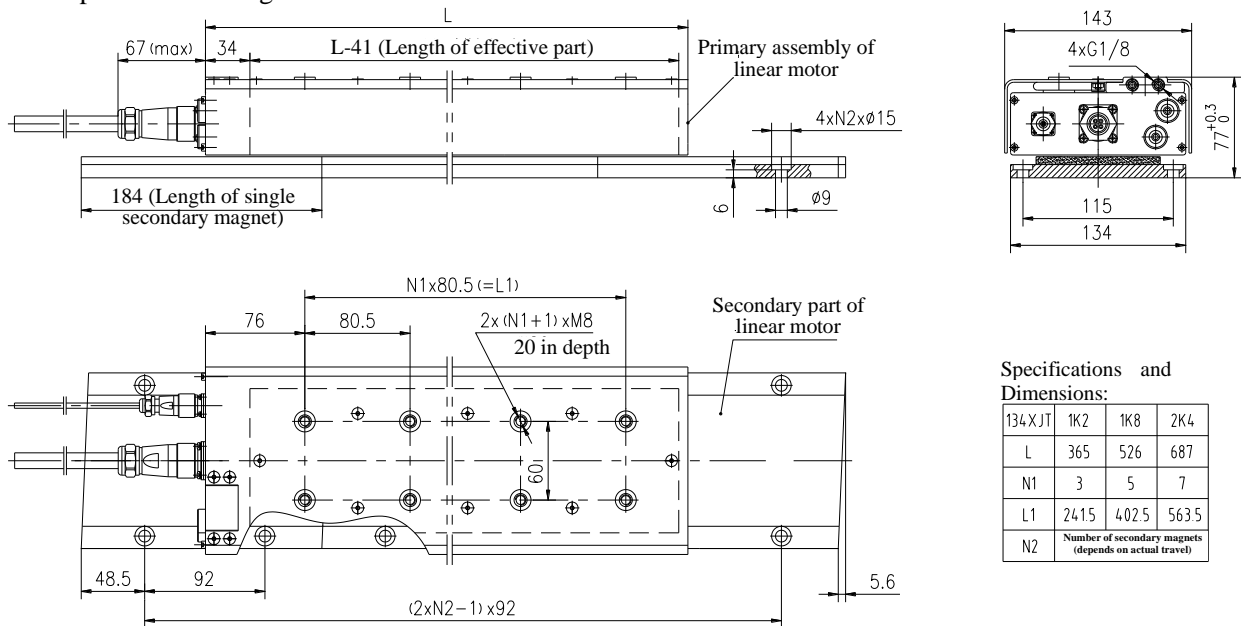

Figure 4

Without precision cooling cover

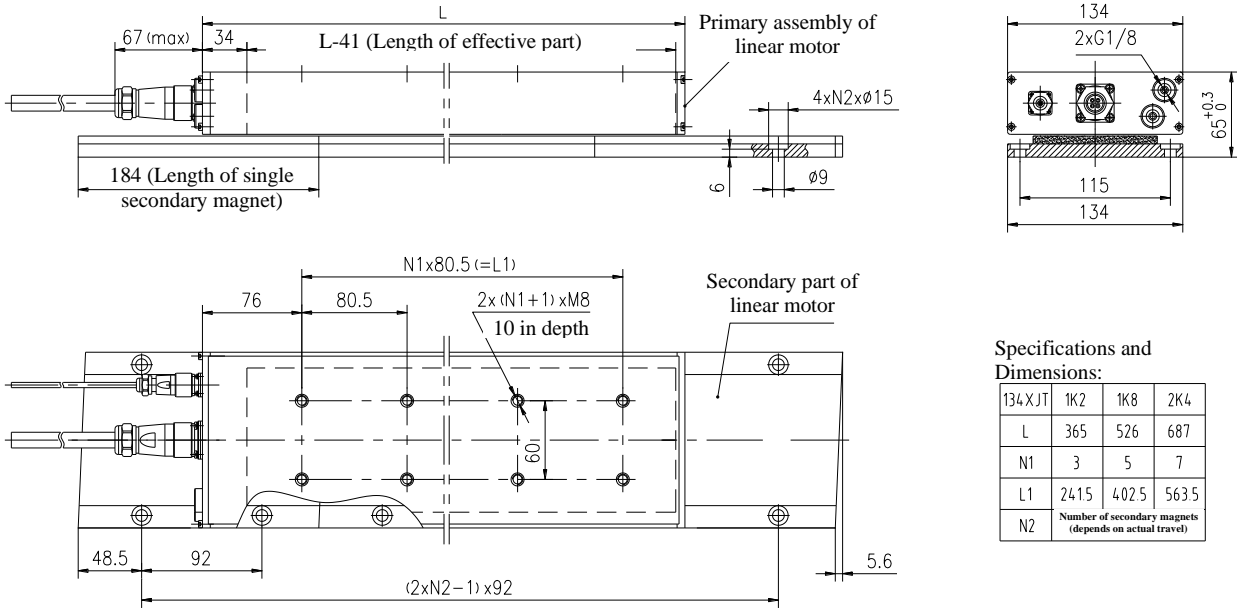

Figure 5

4.4 Outline and Installation Dimensions of 182XJT Series Linear Motor

With precision cooling cover

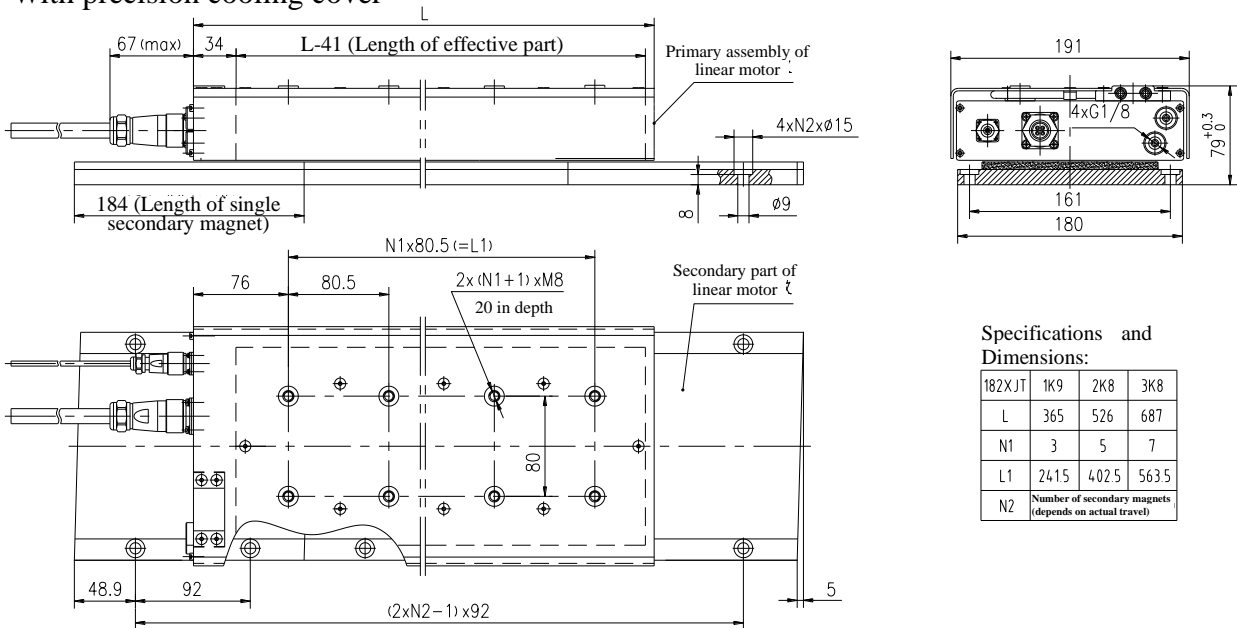

Figure 6

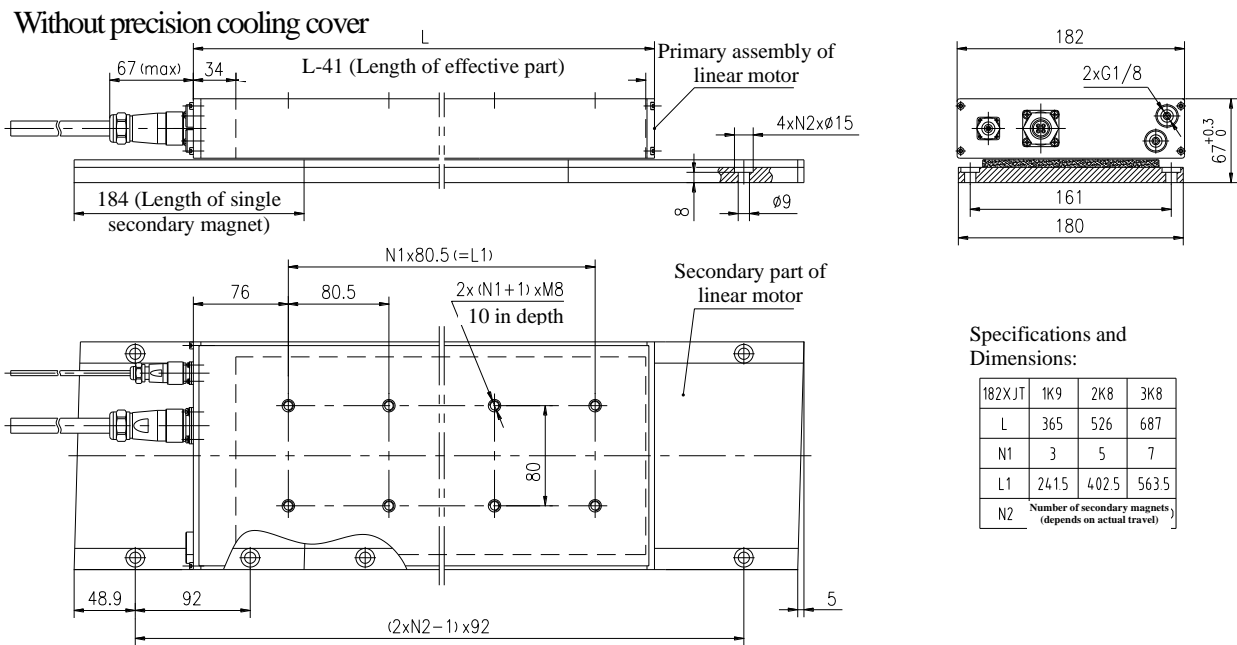

Figure 7

#### 4.5 Outline and Installation Dimensions of 242XJT Series Linear Motor

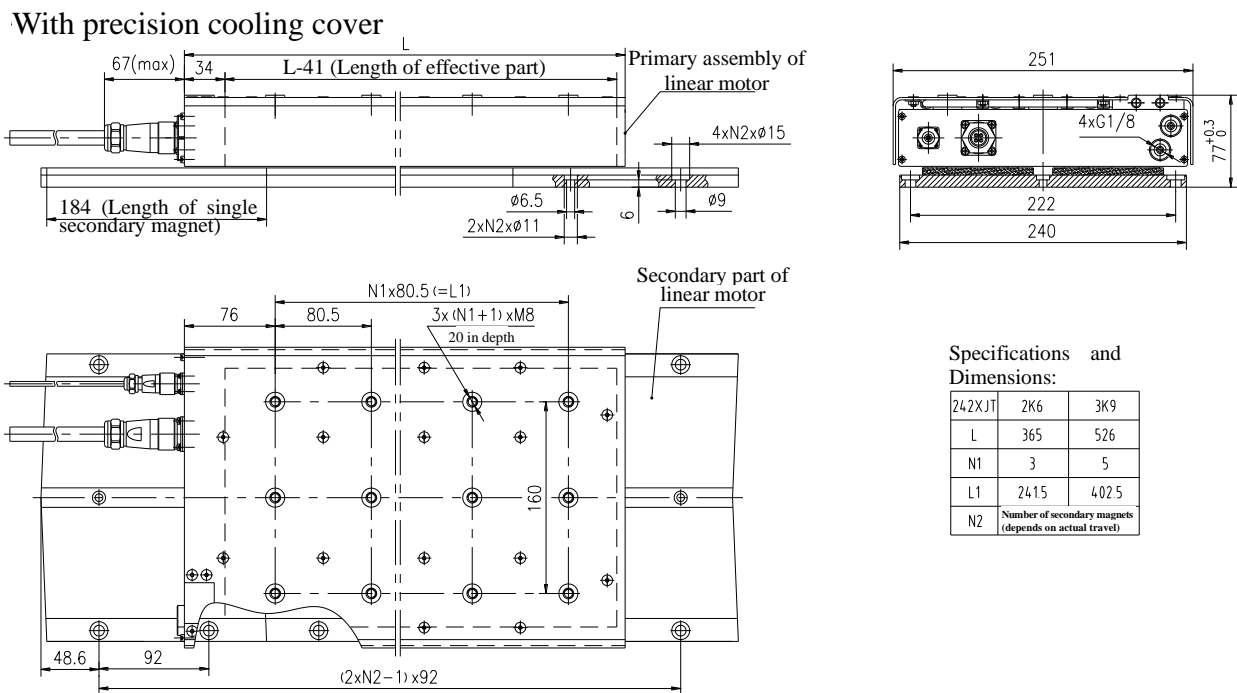

Figure 8

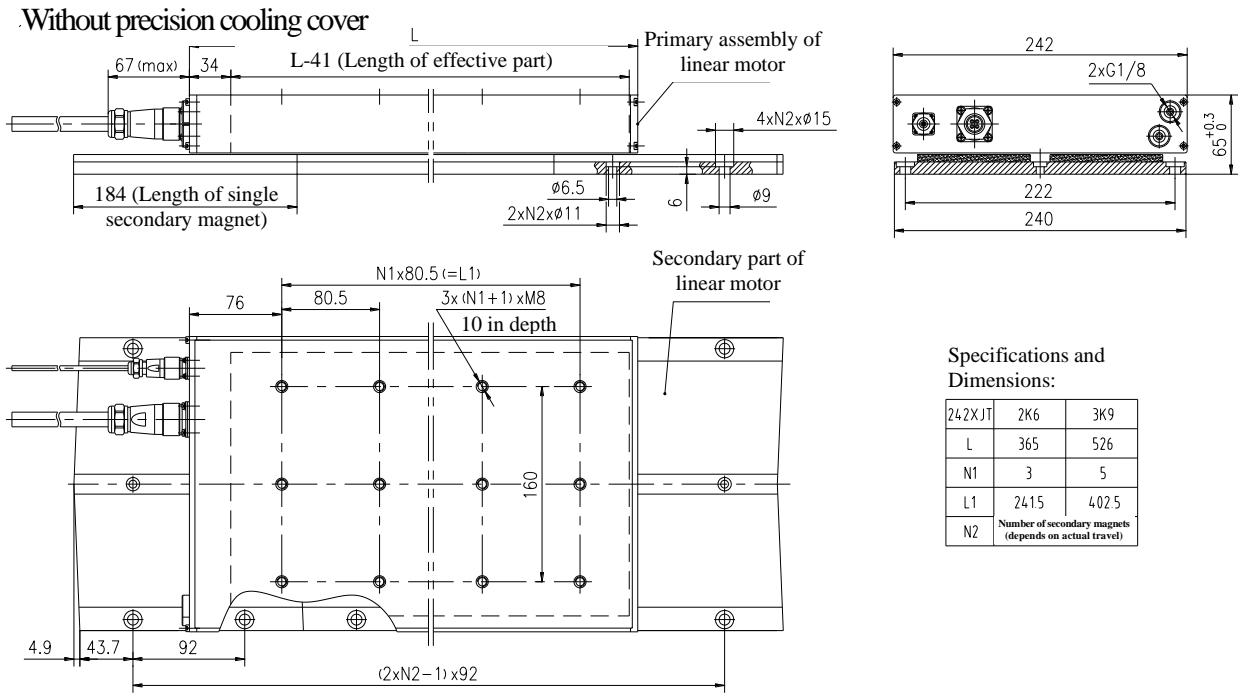

Figure 9

#### 4.6 Outline and Installation Dimensions of 334XJT Series Linear Motor

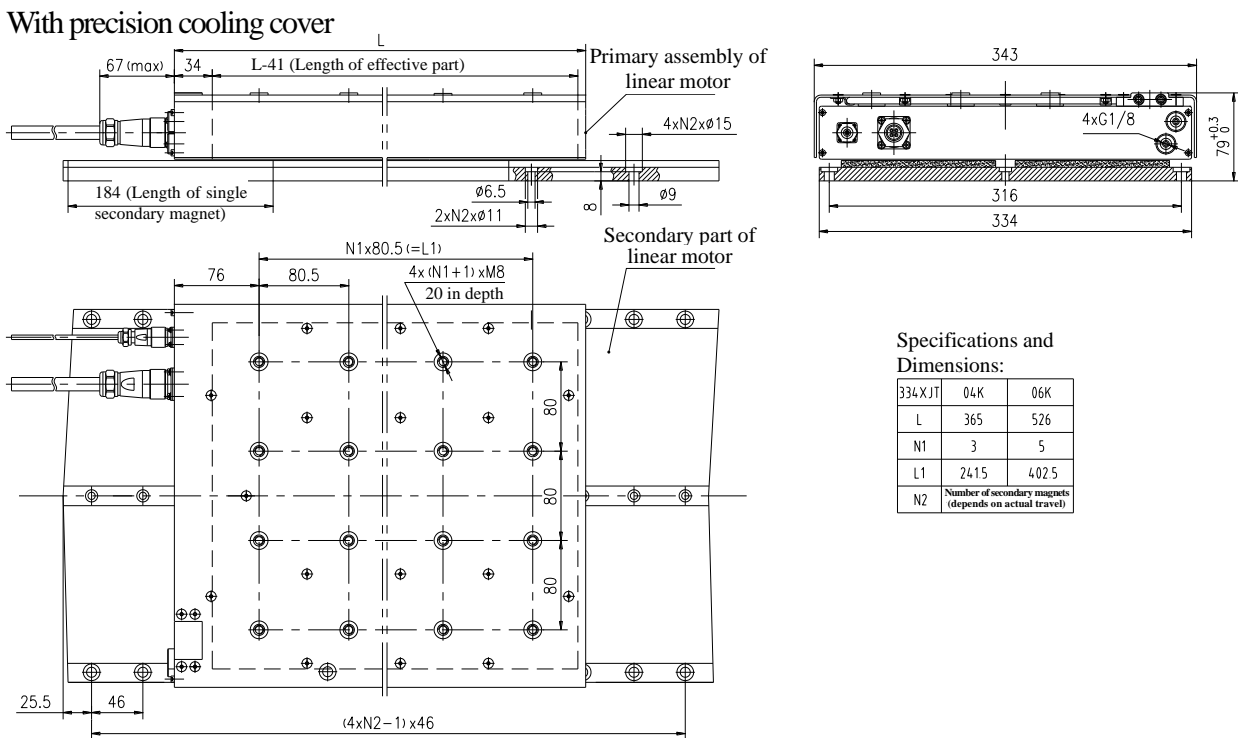

Figure 10

Without precision cooling cover

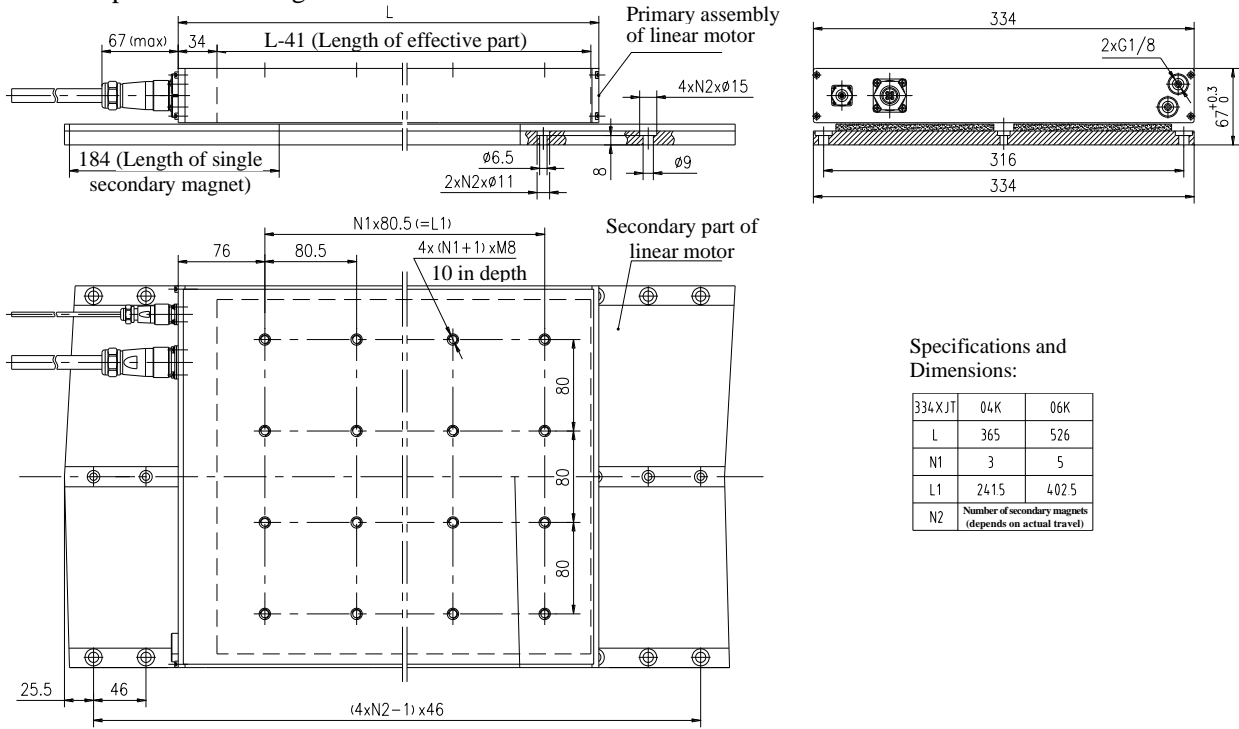

Figure 11

#### 4.7 Outline and Installation Dimensions of 340XJT Series Linear Motor

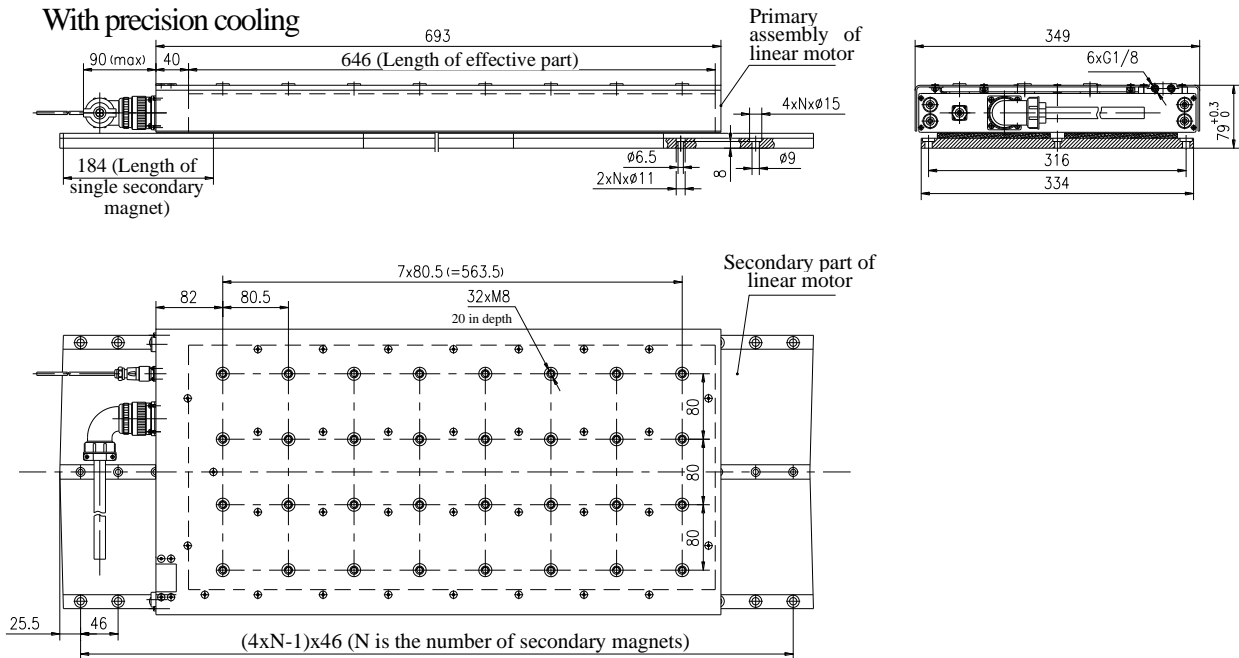

Figure 12

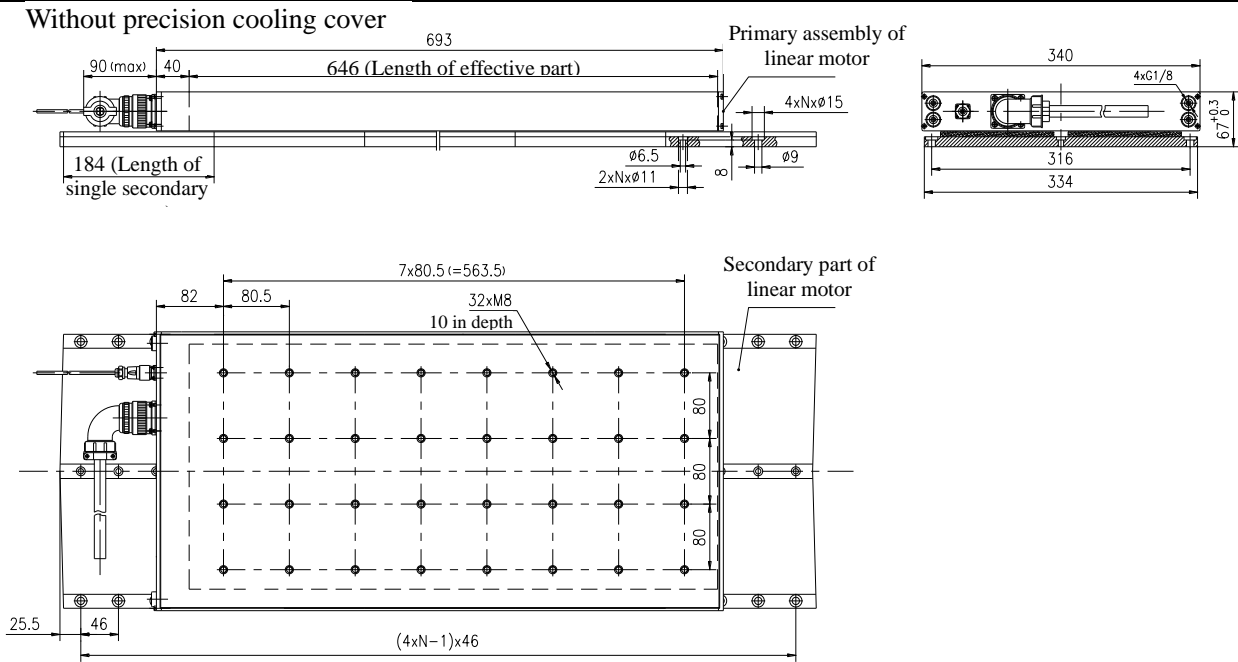

Figure 13

## 5 Installation Requirements and Precautions

### 5.1 Structure of linear motor

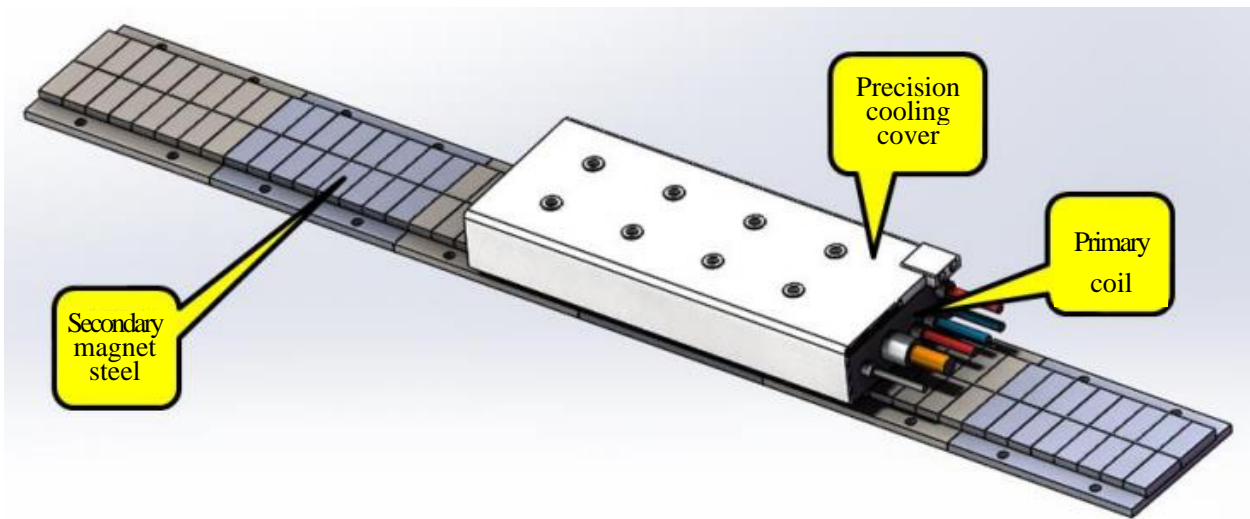

Figure 14

The permanent magnet synchronous linear motor is mainly composed of primary assembly and secondary assembly.

**Primary assemblies:** It mainly includes linear motor winding, temperature measuring elements and internal cooling assemblies.

**Secondary assembly:** The secondary is permanent magnet, namely magnetic steel, used for motor excitation.

It is of a multi-block splicing structure, and the specific length is

determined as required by the travel.

**Precision cooling cover:** the cooling cover is optional, which prevents the heat of the motor from being transmitted to the workbench so as not to affect the machining precision.

## 5.2 Installation layout

When the linear motor is installed for use, in addition to the base, the carriage and the guide rail of the foundation, the linear encoder and necessary protective anti-collision devices must be included. The layout is shown in Figure 15.

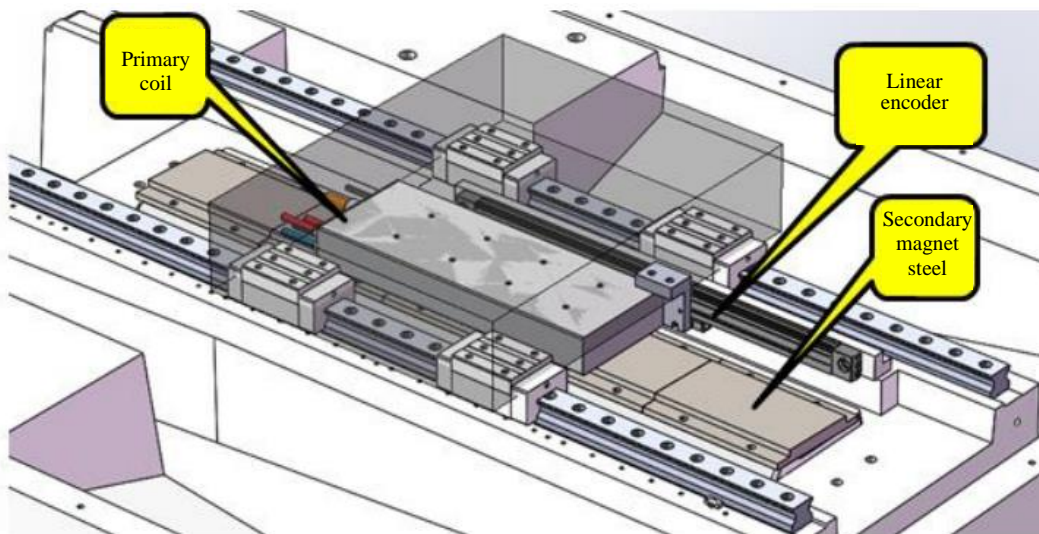
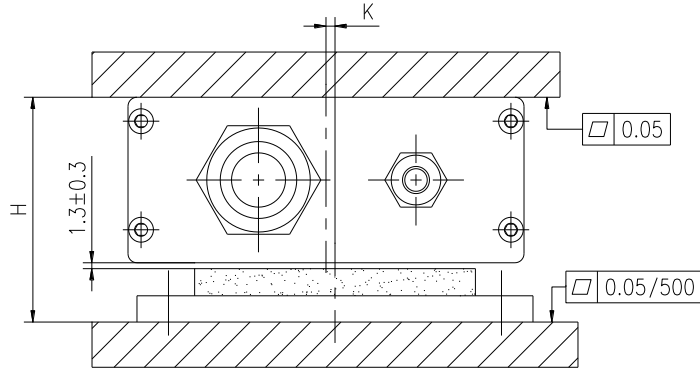

**Figure 15**

**Linear encoder:** It is an indispensable part for linear motor control and the key component for operation control, position detection and feedback. Now, the commonly used linear encoders include grating ruler and magnetic grid ruler. They are usually provided by the customer himself and selected according to the use requirement. At present, our company can provide Heidenhain Endat absolute grating ruler, Fargo SSI absolute grating ruler, Italy GIVI and Changchun Yuheng BiSS(C) absolute grating rulers.

**Anti-collision device:** It is used to prevent misoperation or other accidents during commissioning and operation, and to avoid or reduce the damage of mechanical parts (especially linear encoder).

### 5.3 Installation requirements



XJT Series		Model						
Dimensions (mm)		88XJT	100XJT	134XJT	182XJT	242XJT	334XJT	340XJT
Combination Height H	Without precision	50 <sup>0</sup> <sub>-0.3</sub>	50 <sup>0</sup> <sub>-0.3</sub>	65 <sup>+0.3</sup> <sub>0</sub>	67 <sup>+0.3</sup> <sub>0</sub>	65 <sup>+0.3</sup> <sub>0</sub>	67 <sup>+0.3</sup> <sub>0</sub>	67 <sup>+0.3</sup> <sub>0</sub>
	With precision	/	62 <sup>+0.3</sup> <sub>0</sub>	77 <sup>+0.3</sup> <sub>0</sub>	79 <sup>+0.3</sup> <sub>0</sub>	77 <sup>+0.3</sup> <sub>0</sub>	79 <sup>+0.3</sup> <sub>0</sub>	79 <sup>+0.3</sup> <sub>0</sub>
Centerline Offset K		2±1	0±1					

Figure 16

**Notes:** in order to avoid vibration caused by unbalanced unilateral magnetic pull caused by excessive centerline offset, except that the 88XJT is deliberately enabled to have the offset of 2mm, other models' offset should be controlled within 1mm.

### 5.4 Order of installation

Generally, the primary assembly and precision cooling cover (optional) should be installed first, and then the secondary assembly follows it. The secondary assembly is installed in sections. First, push the sliding plate to one side, install the secondary assembly at the exposed part, and push it to the other end after installation, and then install the secondary assembly of the other end, See Figure 17.

**Note:** when pushing the primary assembly, please make sure that the UVW three-phase cable is not shorted, otherwise it is impossible to push it.

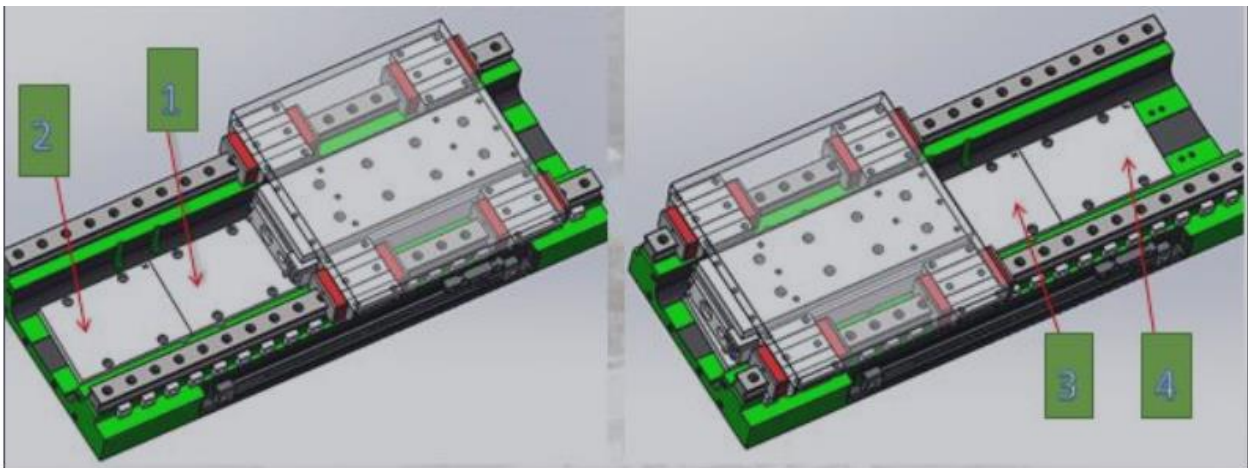

Figure 17



### 5.5 Influence of air gap on continuous thrust

The thrust percentage of linear motor is shown in Table 8 and Figure 18.

**Table 8**

Air gap $\delta$	Model				
	88XJT/100XJT	134XJT	182XJT	242XJT	334XJT/340XJT
1.0	106.60%	105.10%	105.41%	105.37%	105.35%
1.1	104.30%	103.33%	103.53%	103.45%	103.48%
1.2	102.13%	101.61%	101.70%	101.67%	101.68%
1.3	100.00%	100.00%	100.00%	100.00%	100.00%
1.4	97.83%	98.33%	98.28%	98.29%	98.28%
1.5	95.79%	96.73%	96.59%	96.65%	96.61%
1.6	93.75%	95.22%	95.02%	95.10%	95.07%

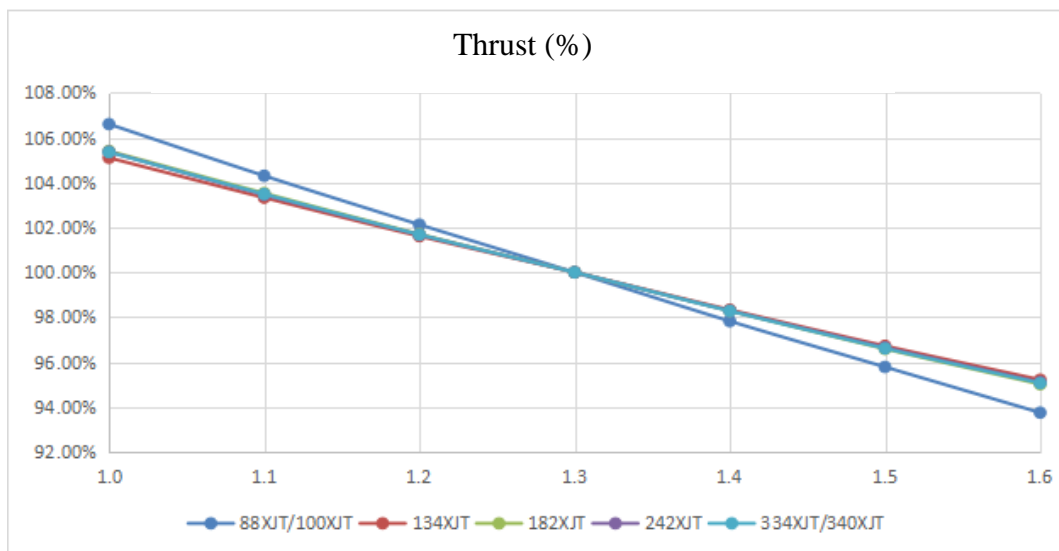

**Figure 18**

### 5.5 Parallel connection

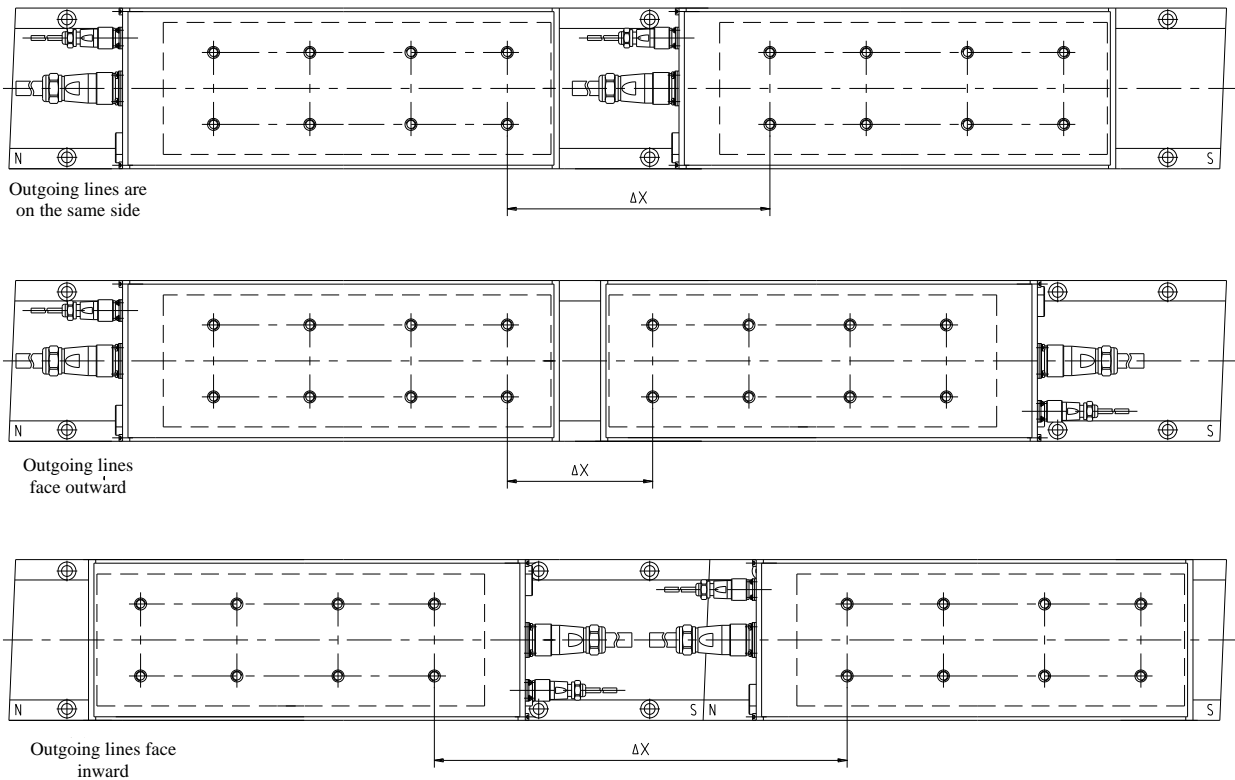

Figure 19

Table 9

Phase Sequence		Outgoing lines are on the same side			Outgoing lines face outward			Outgoing lines face inward		
Linear motor 1		U	V	W	U	V	W	U	V	W
Linear motor 2		U	V	W	W	V	U	W	V	U
Spacing $\Delta x$ (mm)	Polar distance $2\tau=30\text{mm}$	$\geq 180$			$\geq 90$			$\geq 330$		
	Polar distance $2\tau=46\text{mm}$	$\geq 230$			$\geq 138$			$\geq 414$		

### 5.6 Other installation precautions

**5.6.1** There is a large positive suction between primary and secondary assemblies of the linear motor, generally equal to five or six times the continuous thrust of the linear motor. Therefore, sufficient stiffness and strength should be considered in the selection of the guide rail and the design of the sliding seat. In addition, in order to improve the dynamic characteristics of the moving shaft, the mechanical center of gravity should be placed within the range of the linear motor as far as possible, as shown in Figure 20.

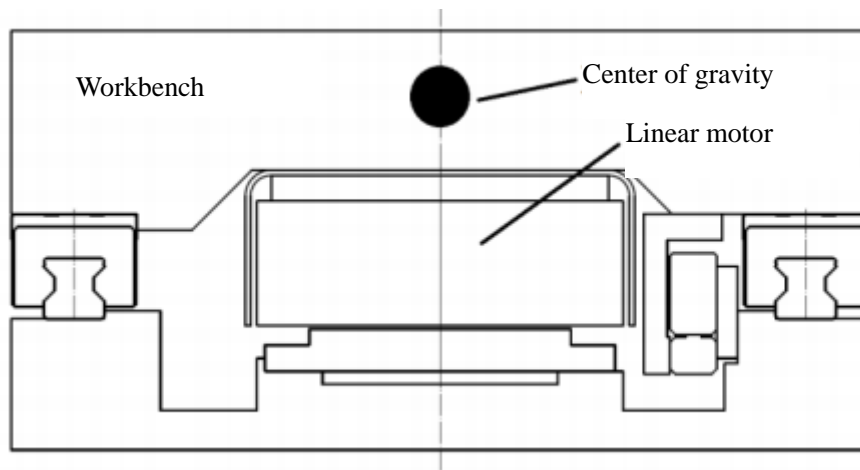

**Figure 20**

**5.6.2** When the linear motor is applied to a vertical or inclined shaft, without the "Servo-On", the motor will fall due to the action of gravity, so it is necessary to design balancing and braking devices. (Please refer to Application Guide of GSK XJT Series Permanent Magnet Synchronous Linear Motor for selection of specific balancing and braking devices.)

## **6 Type Selection of Linear Motor**

### **6.1 Calculation method for type selection of linear motor**

Calculation for type selection of the linear motor is greatly different from that of the rotating motor, and the common steps are given as follows:

- 1) In combination with the structure of the machine, the installation space of the linear motor is estimated, and the linear motor frame No. is restricted;
- 2) The linear motor is pre-selected according to weight, operation speed, acceleration and other indicators of the moving parts of the machine;
- 3) The motor model and its specification are finally determined as per the pre-selected linear motor parameters.

The calculation method is relatively complex. You can first determine the mechanical parameters and fill in the type selection analysis form provided by our company for verification, as shown in Figure 21. The analysis form is shown below. Please fill in the mechanical and operating parameter information in the yellow cells, and select the motor model, so as to automatically calculate the adaptability of the motor.

Type selection analysis of linear motor

Selection Result				Conclusion: Selected motor: 134XJT1K2M10W <b>Meet</b> the use requirements under the current set conditions.
Item	Motor parameters	Analysis result	Ratio	
Maximum speed n/min	150	50	33%	
Peak thrust N	3000	1653	55%	
Continuous thrust N	1200	779	65%	
Item	Parameters		Remarks and description	
Service conditions	Weight of shaft moving components:	140 kg	Mass of shaft moving components, excluding motor  Fill 0° for horizontal shaft Linear guide rail: 0.02/hard rail: 0.1 Estimate the resistance of cable, drag chain and protective cover	
	Travel	0.45 m		
	Maximum movement speed	50 m/min		
	Maximum acceleration	9.81 m/s*s		
	Inclination angle	30°		
	Friction coefficient	0.02		
	Resistance	20 N		
	Safety factor	1.2		
Option of inclined axis or vertical axis	Is balancing device equipped?	Yes	Select via dropdown list	
	Balance coefficient (balance ratio)	1	0 for no balancing device, 1 for full balance.	
Motor selection	Motor model	134XJT1K2M10W	Select via dropdown list	
	Installation mode of motor	Primary assembly movable - secondary assembly fixed	Select via dropdown list	
	Specifications of primary assembly	134XJT1K2M10-00		
	Specifications of secondary assembly	140XJTS4-01		
Motor parameters	Quantity of secondary assembly	5		
	Rated power	1.2 kw		
	Continuous thrust	1200 N		
	Peak thrust	3000 N		
	Magnetic attraction	6800 N		
	Maximum speed	150 m/min		
	Weight of moving part:	12 Kg		

Figure 21

## 6.2 Type selection of linear motor matching drive

The linear motor shall be equipped with the GR series drive unit, and the 380V linear motor shall be equipped with the GR3000 drive unit. The type selection is based on the peak current of the linear motor:

$$\frac{\text{Drive module voltage} * 0.85}{1.414} > \text{Peak current of linear motor}$$

For example, the 134XJT1K2M10W linear motor has a peak current of 21A, the GR3050 drive unit can be selected,

$$(50*0.85)/1.414=30>21, \text{ so it meets the requirement.}$$

## 7 Calculation of Heating Power and Selection of Water Cooler

### 7.1 Installation of cooling water pipelines for the linear motor

When a water-cooled linear motor is used for multiple shafts, the cooling pipelines must be installed in parallel. Besides,

Due to the high heating power of the 340XJT series, a single motor needs two loops, as shown in the figure below, as shown in Figure 22.

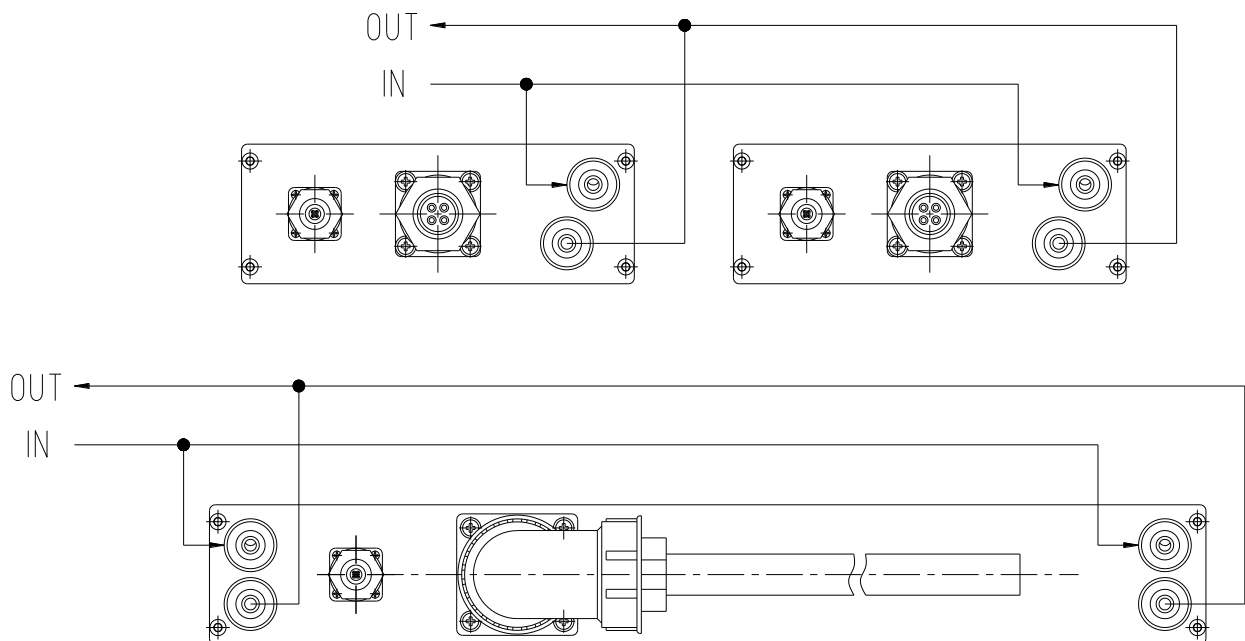

Figure 22

## 7.2 Calculation of heating power of linear motor

Since the energy consumption of linear motor during operation is mainly copper consumption, the heating power can be approximated as its copper consumption. The calculation formula is as follows.

$$P_{Cu} = 3 * I^2 * R = 3 * \left( \frac{F}{F_N} * I_N \right)^2 * R$$

For example, the continuous thrust F calculated as per the type selection of the linear motor in Section 6.1 is equal to 779N, Fn of the 134XJT1K2M10W motor equals to 1200N, In=8A, R=4.73 Ω at 120 °C, so the copper consumption of this motor under the calculation working condition is derived as follows.

$$P_{Cu} = 3 * I^2 * R = 3 * \left( \frac{F}{F_N} * I_N \right)^2 * R = 3 * \left( \frac{779}{1200} * 8 \right)^2 * 4.73 = 382.7 (W)$$

## 7.3 Selection of water cooler

The water cooler is selected based on the following two criteria:

- 1) The refrigerating power shall be greater than the total heating power of the linear motor:

$$P_{refrigeration} > \sum P_{Cu}$$

- 2) The minimum flow of the water cooler shall be greater than the sum of the minimum flows of the linear motors:

$$Q_{Water\ Cooler} > \sum Q_{Motor}$$

## 8 Cables of Linear Motor

### 8.1 Temperature protection

Two sets of temperature sensors are embedded in the linear motor. One is the KTY84/130 silicon thermistor, mainly used to monitor temperature changes; the other is PTC130 overheat protection temperature sensor, used for overheat and power-off protection of the internal of winding.

### 8.1.1 KTY84/130 silicon thermistor

The electrical parameters of KTY84/130 silicon thermistor are shown in Table 10, and the temperature resistance characteristic curve and configuration diagram are shown in Figure 23.

**Table 10**

S/N	Electrical parameters	Symbol	Test condition	Minimal	Standard	Maximum	Unit
1	Resistance value at 25°C	R <sub>25</sub>	Constant temperature 25°C±0.05°C	577	603	629	Ω
2	Resistance value at 100°C	R <sub>100</sub>	Constant temperature 100°C±0.05°C	970	1000	1030	Ω
3	Insulation resistance	/	DC=100V	100	/	/	MΩ
4	Max. operating current	I <sub>max</sub>	/	/	/	8	mA
5	Rated operating current	I <sub>n</sub>	/	/	5	/	mA
6	Operating temperature	T <sub>a</sub>	-40°C~210°C				

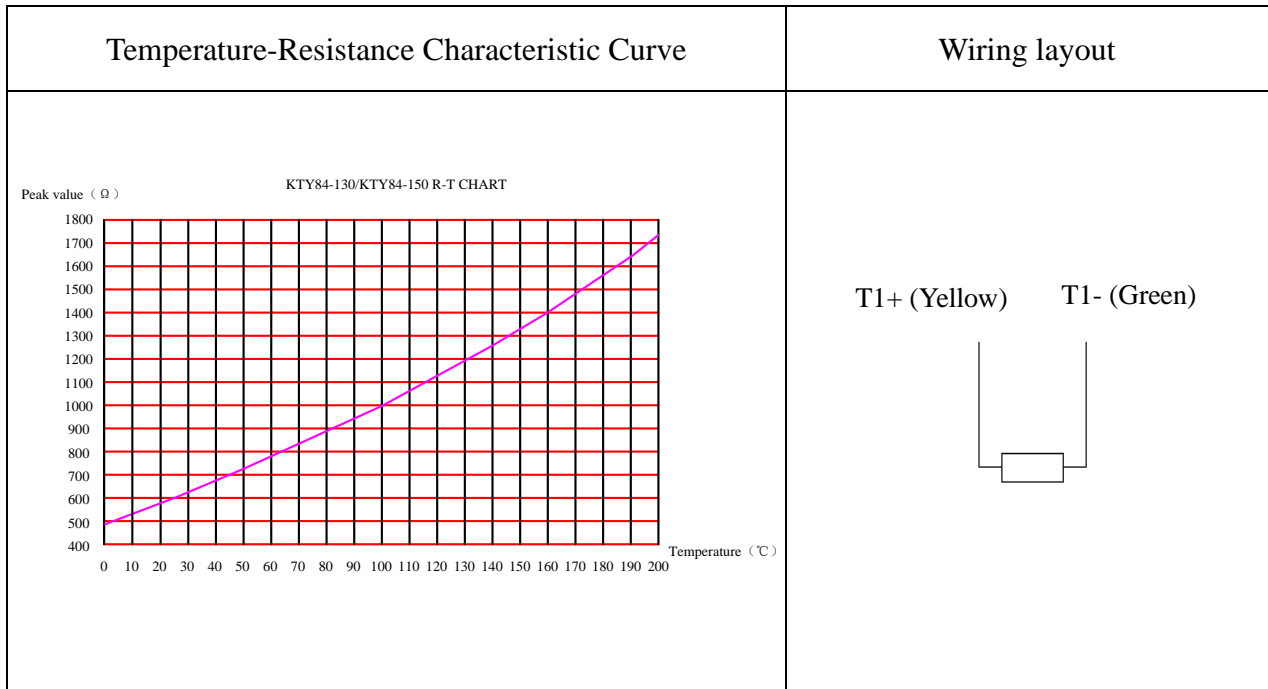

**Figure 23**

### 8.1.2 PTC130 overheat protection temperature sensor

The electrical parameters of the PTC130 overheating protection temperature sensor are shown in Table 11, and the temperature resistance characteristic curve and configuration diagram are shown in Figure 24.

**Table 11**

S/N	Item	Technical Requirements
1	Max. DC operating voltage	30Vdc
2	DC voltage/current during normal use	Voltage $\leq$ 2.5V/ Current $<$ 2mA
3	Temperature control precision	$\pm$ 5 $^{\circ}$ C
4	Resistance $R_{25}$ at room temperature ( $T=25^{\circ}$ C $\pm$ 1 $^{\circ}$ C)	$\leq$ 100 $\Omega$
5	TK+5 $^{\circ}$ C	$\geq$ 1330 $\Omega$
6	TK-5 $^{\circ}$ C	$\leq$ 550 $\Omega$
7	TK+15 $^{\circ}$ C	$\geq$ 4000 $\Omega$
8	-20 $^{\circ}$ C $\sim$ TK-20 $^{\circ}$ C	$\leq$ 250 $\Omega$
9	Test voltage (DC)	$\leq$ 2.5Vdc
10	Response time	$<$ 5s
11	Insulation strength (AC)	2.5kV/60s
12	0.12mm <sup>2</sup> Lead	$\leq$ 0.15 $\Omega$ /m

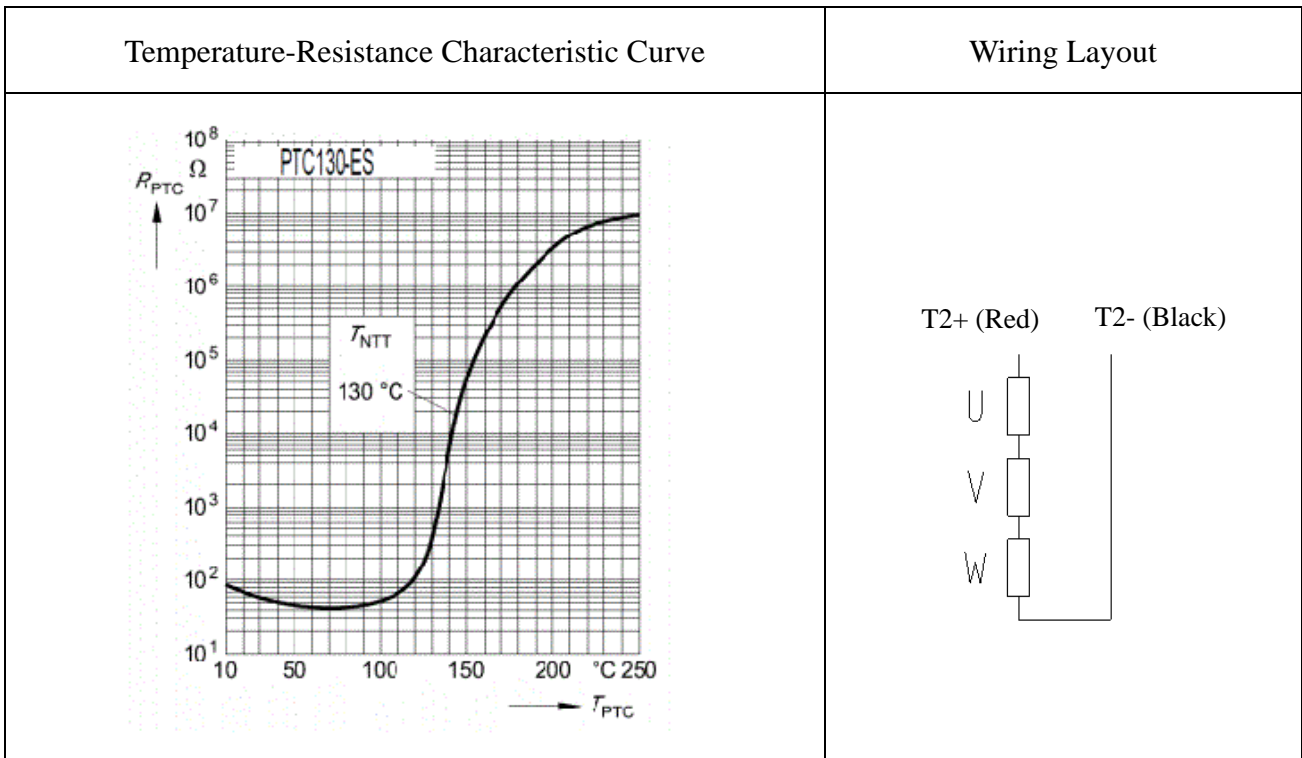

**Figure 24**



### 8.2 Temperature control signal line (XJT-00-701)

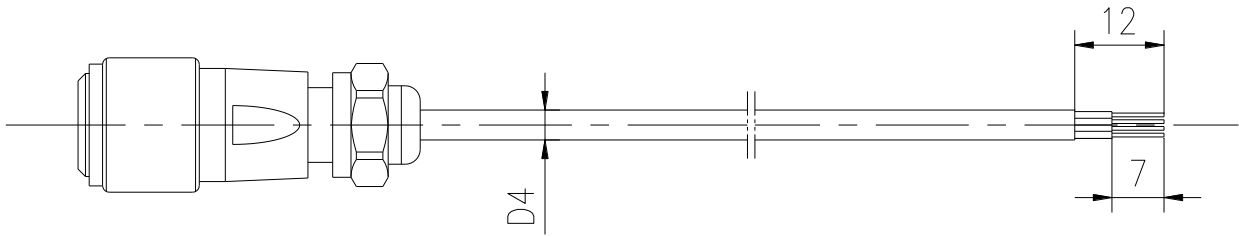

Wiring Table

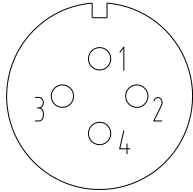

Sensor model	KTY84/130		PTC130	
Sheath color	Yellow	Green	Red	Black
Plug pin No.	1	2	3	4

Figure 25

### 8.3 Power cord

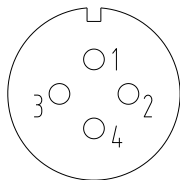
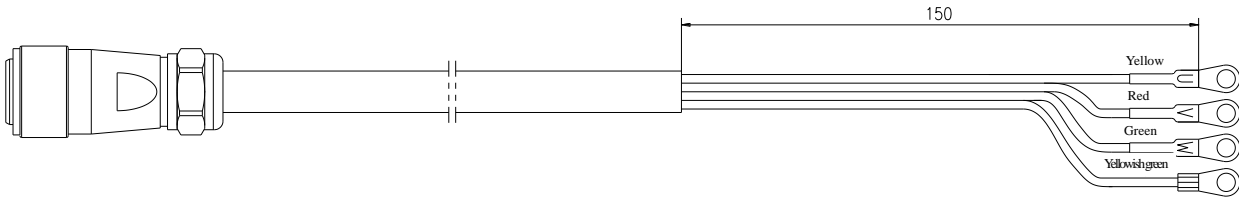

Wiring Table

Color of power cord	Yellowish green(ground)	Yellow (U)	Red(V)	Green (W)
Plug pin No.	1	2	3	4

Figure 26

Table 12

Power Cord	Available Continuous Current (A)	Cable Diameter (mm)	Minimum Bending Radius (mm)
XJT-00-702	<15	φ12	50
XJT-00-703	<25	φ13	50
XJT-00-704	<35	φ21	80

## 9 Storage of Linear Motor

The linear motor shall be stored in a clean and well ventilated warehouse with an ambient temperature of  $-40\text{ }^{\circ}\text{C} \sim 55\text{ }^{\circ}\text{C}$  and a relative humidity of not more than 95% (no condensation), and the air shall not contain corrosive gases.

## 10 Transportation of Linear Motor

During transportation, please handle products with care and avoid collision and impact. It is strictly forbidden to put them together with corrosive substances such as acid and alkali; It shall not be transported in the open air, and attention shall be paid to waterproof, rain and snow proof, dust-proof prevention and mechanical damage.

## 11 Warranty Period

**Under the condition that the user complies with transportation, storage, installation, commissioning and repair of the product and with the use procedures, the Company is responsible for repairing the linear motor free of charge if it is damaged or cannot be used normally due to poor manufacturing quality within 12 months from the date of delivery (based on the delivery certificate).**

## 12 Order Description

The linear motors listed in these operation instructions are of the models and specifications recommended by the Company, which can be applicable to most applications. If you have other demands, we can provide linear motors of other specifications according to your demands.